

Installation Manual



La Escandella

ROOFING THE WORLD



TECHNICAL EDIFICATION CODE (Spain)



MEDITERRANEAN



H-SELECTION



La Escandella

ROOFING THE WORLD



www.laescandella.com

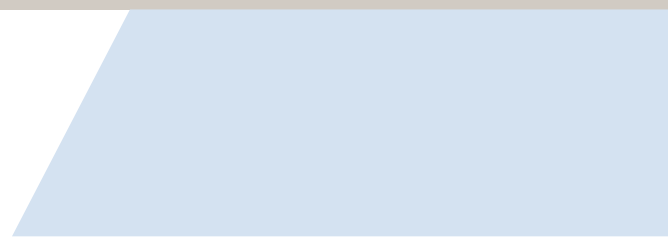

INDEX

00	Why La Escandella?	04
01	Clay Roof Tile	07
	Clay Roof Tile	08
	Types of clay roof tiles	10
02	Types of roof and and roofing components	13
	Types of roofing for different geometries	15
	Types of roofing depending on ventilation needs	16
	Roof Elements	17
	Types of Roof Support	18
03	Getting Started	23
	Geografic Area	25
	Climatic Zones	25
	Prior inspection of the field	26
	Slopes / Pitches	27
	Fixing needs and components	29
	Ventilation and waterproofing	30

04	Installation by tile type	35
	4.1 Mechanical tiles	36
	- MEDITERRANEAN TILES	
	- Mixed roof tile (TG/TP)	38
	- Flat roof tile (TL)	42
	- Accessories (TG / TP / TL)	44
	- H-SELECTION	
	- Innova roof tile (TN)	48
	- Vienna roof tile (TV)	50
	- Planum roof tile (TI)	52
	- Visum3 roof tile (TW)	54
	- Accessories (TN / TV / TI / TW)	56
	- Installation details	58
	· Side courses	58
	· Ridge	62
	· Eave	70
	· Hip	76
	· Valley	78
	· Vertical walls	79
	· Pitch change	82
	· Chimneys and ventilation ducts	83
	· Window´s roof and skylights	84
	· Other	85
	4.2 Curved roof tile	86
	- Accessories	88
	- Underlayment support	90
	- Fixation Systems	90
	- Laid method	91
	- Installation details	94
	· Side courses	94
	· Ridge	95
	· Eave	96
	· Hip	97
	· Valley	97
	· Vertical walls	98
	· Pitch change	99
	· Chimneys and ventilation ducts	100
	· Window´s roof and skylights	101
	Summary of Accessoires per format: Mediterranean tiles	102
	Summary of Accessoires per format: H-Selection tiles	104

05	Roofing components	107
	Waterproofing	110
	Ventilation	112
	Waterproof Membranes	113
	Fixation Systems	114
06	Roof maintenance and care	117
07	Glossary	123

Why La Escandella?

La Escandella's growth rate, together with the success of projects it has undertaken in recent years, is proof that it's a rising star in our sector. Over the last ten years, La Escandella has consolidated its position as market leader in Spain and one of the main manufacturers in the European arena, on the strength of R&D&I investments and new product developments that reflect the requirements, habitat and architectural style of each market it is present in.

Production Capacity

Located next to the Mediterranean Sea, La Escandella's plant offers the largest on-site production capacity worldwide. Our 55.000m² manufacturing facility ensures that the company can react immediately to any need, anywhere in the world.

La Escandella's production, operations and logistics processes, together with its storage space of 230,000 m² and an average in-stock level of 240,000 pallets, have been designed to be able to respond immediately to the demands of our customers.

Pursuit of Innovation

From the outset, La Escandella has worked on the principle of constant incorporation of the latest technological innovations into its production processes. This means we have the most advanced installations on the market.

Wide Range of Products

La Escandella's versatile range includes seven main tile shapes: The Mixta, the Curva, the Plana, the Visum3, the Planum, the Vienna and the Innova. These styles come in the widest range of attractive colours, covering every type of architectural requirement, from colonial-style to the most contemporary buildings.

These products are complemented by a huge range of special pieces and roof accessories, which make installation easier and give a perfect, polished finish to the roof.





Unparalleled quality

During the production process we submit each item to rigorous and daily quality control checks. This ensures that Cerámica La Escandella's roof tiles comply with a strict national standard, and are guaranteed to carry out the purpose of its intended use.

La Escandella roof-tiles have achieved the best ratios into the values required by the European quality control standard for baked clay tiles, highlighting the NF (AF-NOR) brand for ceramic tiles and complying with the European Standard EN1304, American ICC-ES ESR 2727 and also the Australian, all of which are completed by the 35-Years Warranty guaranteed in all of its tiles and accessories (Mediterranean Range) as well as the 100-Years Warranty of its H-Selection Range.

Commitment to the environment

Cerámica La Escandella is totally committed to protecting and conserving the environment. These values are reflected in the way it uses a cogeneration power station to minimize its energy consumption, thereby making its kilns and driers cleaner and greener.

La Escandella Worldwide

La Escandella is present in over 70 countries spread over all continents. We are an entrepreneurial company that offers true quality, as our track record and international projects testify.

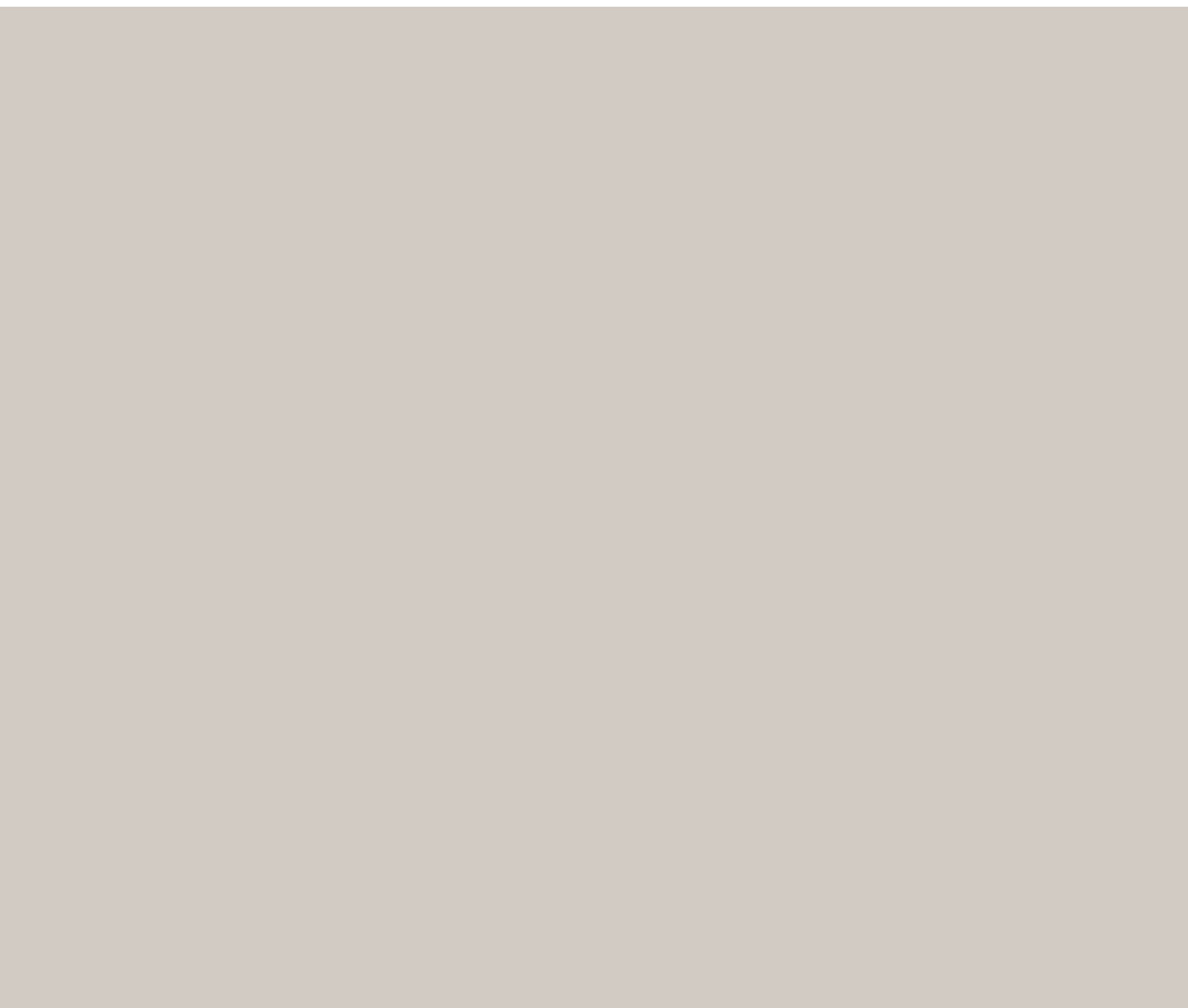

Clay Roof Tile

01



Clay Roof Tile

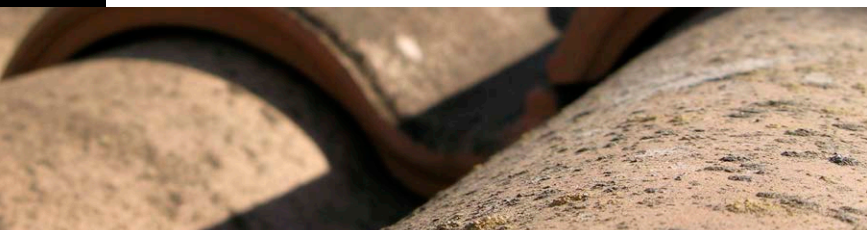

Throughout history, roofs have played a fundamental role in protecting and decorating homes. They have allowed us to protect buildings from the elements, while helping blend them into their environmental and architectural surrounds using a variety of colours and shapes.

Specifically, ceramic tile roofs carry out the following functions:

- **Waterproofing.** The principle purpose of a ceramic tile roof is to prevent water from entering the building, protecting it from rain, snow, frost and hail. The correct slope and the tiles themselves ensure that a roof is watertight.
- **Thermal insulation.** Roofs can be submitted to extremes of heat and cold. To ensure correct hygrothermal behaviour, a roof must be correctly built, so that it provides energy savings and comfort.
- **Fire Performance or Fire Resistance (A1).** The roof provides protection from lightening and various rays, so the tiles and materials must be fireproof.
- **Load resistance.** The roof must support occasional heavy weights, such as snow or people accessing it.
- **Wind and vapor tightness.** (avoid condensation) The roof provides shelter from strong winds and safeguards against internal condensation from homes, so it must be perfectly ventilated in order to avoid damage to the foundations.
- **Sound isolation.** It provides insulation against both internal and external noise.
- **Go Green.** Clay Roof Tiles are made from natural materials: they are recyclable, energy consumption for their production is lower than that required for other materials, and they are chemically inert and do not corrode. Their design and raw materials work in aesthetic harmony with their surroundings.

Properties of clay roof tiles

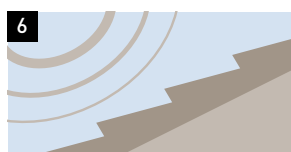
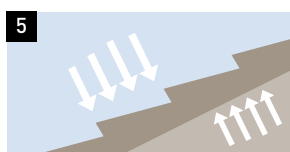
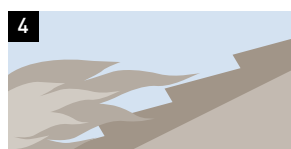

1. Water tightness
2. Thermal insulation
3. Frost Resistance
4. Fire Performance or Fire Resistance
5. Air tightness and vapor
6. Sound isolation
7. Aesthetic and harmonised with their surroundings
8. Go Green

Factors that have an impact on roofs

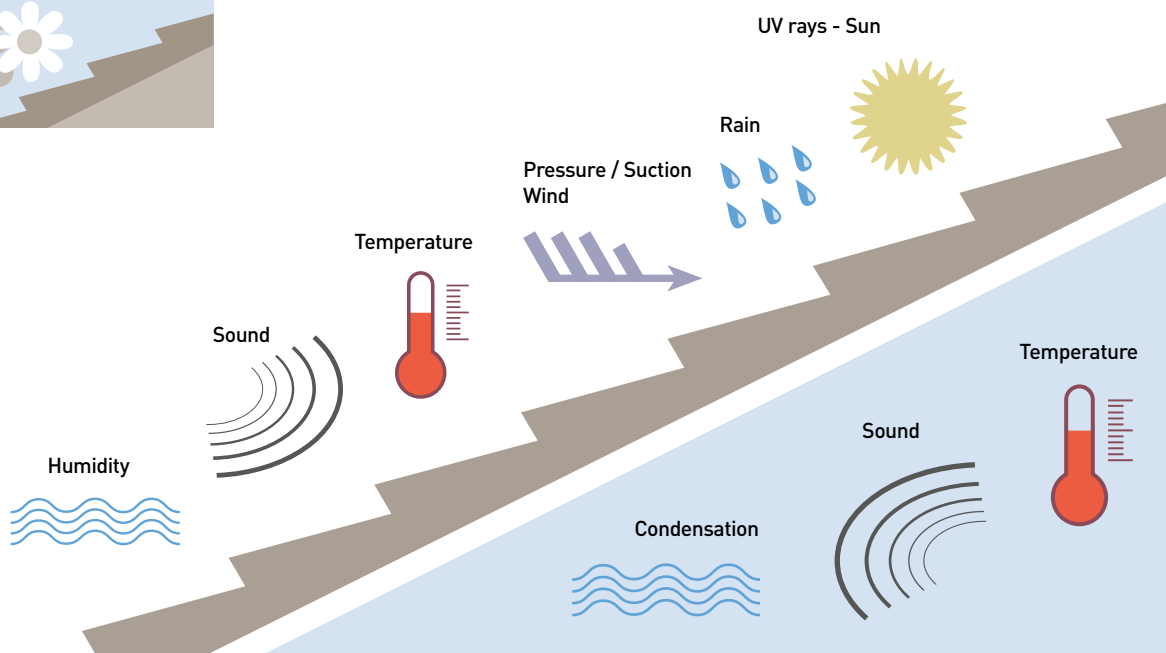

Types of clay roof tiles

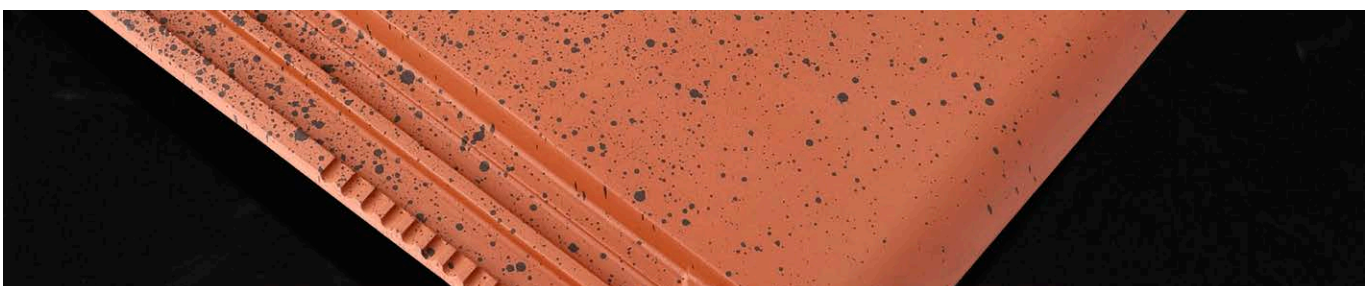

Curved roof tile

Curved tiles are roofing elements in the form of a gutter. Their design allows variable overlapping between pieces. Their edges may be parallel or conical.

Available in three different formats, they are used in the construction of new homes for the beauty and variety of their colours.

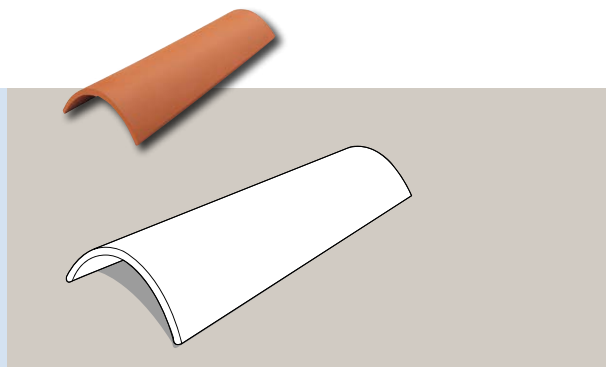

Mixed roof tile

These are double curved “S” roof tiles, with a longitudinal and transversal interlocking system, so that the laid tiles provide a seal in both the vertical and horizontal courses.

A double curvature mixed “S” roof tile where eaves and ridge tiles assure design and functionality to provide easy-to-install roofs with the special characteristic beauty of the Mediterranean roofs

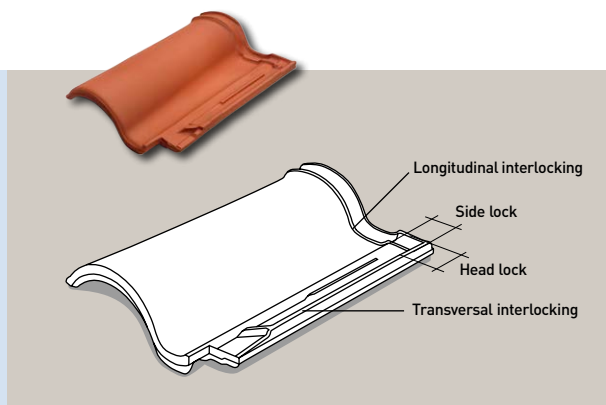

Flat roof tile

These are flat profile tiles, with a ribbing system for longitudinal and transversal interlocking.

A versatile and easy-to-fit roof tile. As there are bigger pieces, the installation and material costs are consequently reduced, enhancing the elegance and durability of this kind of roof tile.

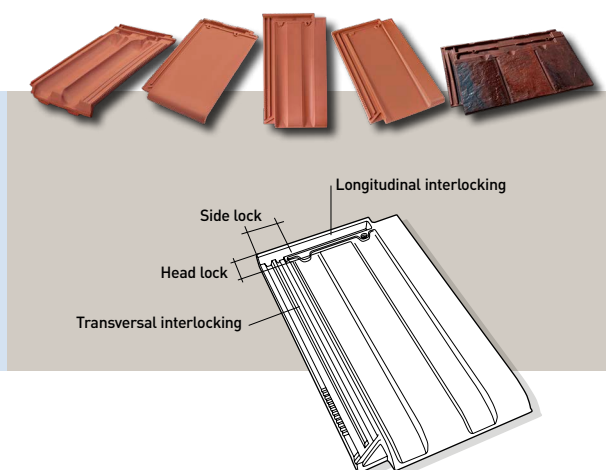



02

Types of roof and roofing components





Types of roof and roofing components

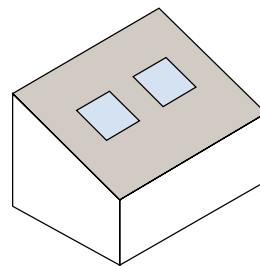

Roof with in-plane /
Out-of-plane skylight

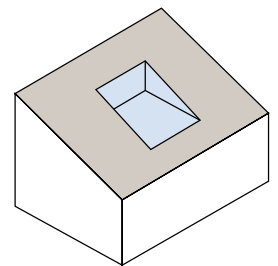

Glazed roof / Roof lantern

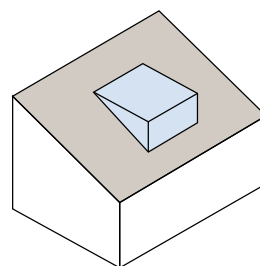

Shed / Pent roof

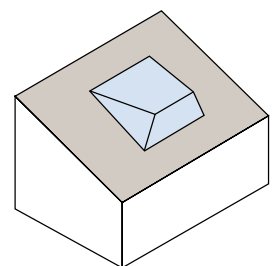

Mansard Roof

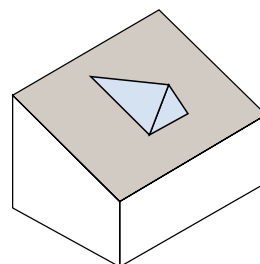

Triangular Mansard

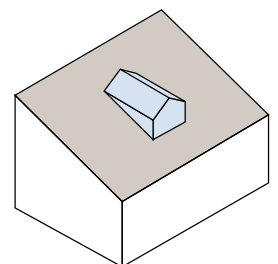

Gabled dormer

Types of roofing for different geometries

When planning a roofing project, all the details that ensure the home is well protected against external aggression must be taken into account. Special care must be taken over the correct evacuation of rain water; the effect of winds; what the minimum slope is depending on the geographic location; ventilation, and correct fi-

xing of the parts, to comply with norm UNE-136020, Code Of Practice For The Design And Fixing Of Roofs With Clay Roofing Tiles.

There are many different types of roof, although most are combinations of the main four:

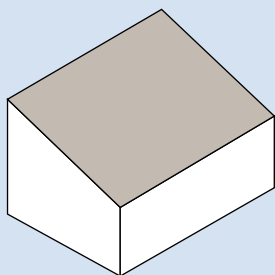

Monopitch

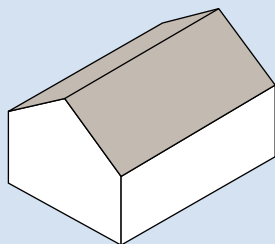

Double pitch

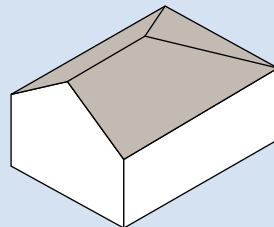

Triple pitch

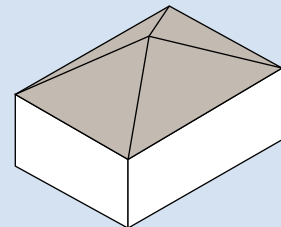

Four Pitch

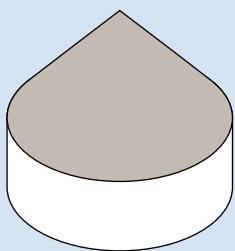

Conical Roof

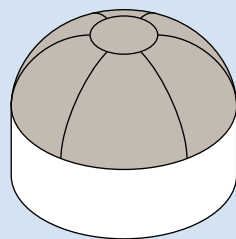

Dome Roof

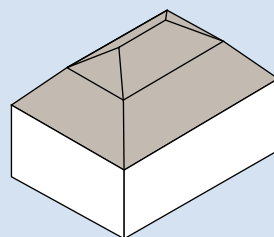

Gambrel roof

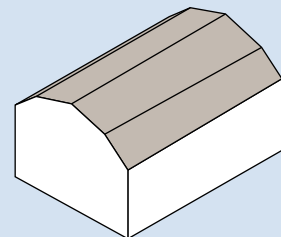

Straight mansard roof

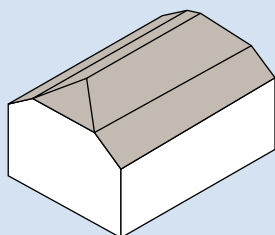

Gambrel roof / Roof with eyebrow dormer

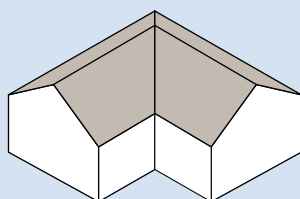

L- shape roof

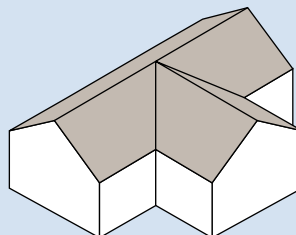

T- shape roof

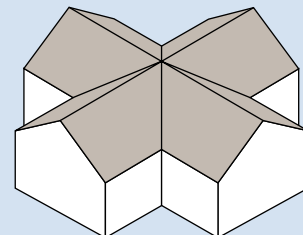

Double pitch crossing roof

Types of roofing depending on ventilation needs

Ventilation is a differentiating factor in the control of a roof's hygrothermal behaviour. The level of ventilation is a deciding factor, and must be adequate to ensure that the humidity levels remain below saturation point.

Non-ventilated Roof

This is made up of a single sheet formed from several layers, which separates the interior of the building from the exterior, without any intermediary air-space (attic or loft). This roof is subjected to strong temperature and water-pressure differences between its interior and exterior surfaces.

Ventilated Roof

This is made up of two sheets, made from several layers, which are separated by a ventilating air space (attic or loft). This space regulates the roof's hygrothermal behaviour, which ensures that the roof is more functional and is recommended.

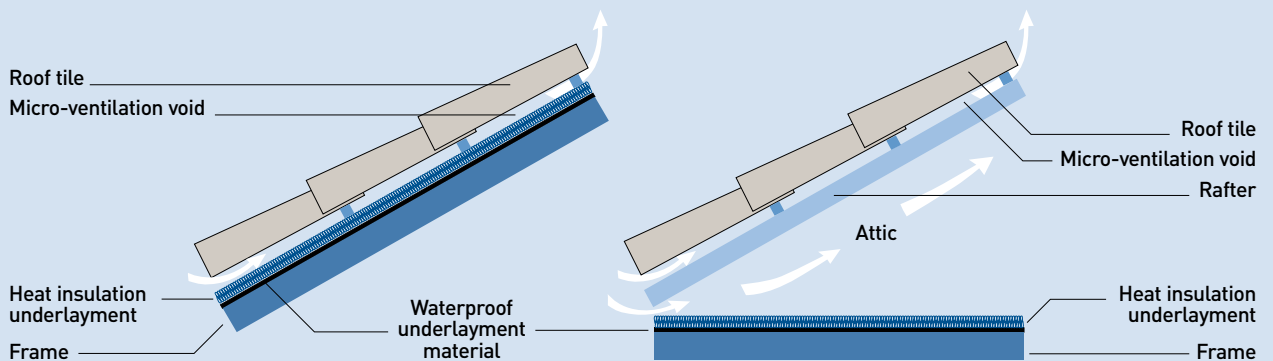

If the attic is to be used as a habitable space, the supporting roof structure must have a sloping plane such that the attic is of a regular section and its slope is parallel to the micro-ventilation layer.

Roof Elements

- **Field or skirt:** Each of the sloped planes that form the roof.
- **Maximum slope line:** The trajectory described by the free flow of water down a field
- **Eave:** The overhanging edge of the slope of a roof. It prevents the water collected by the roof from falling on the vertical wall
- **Right of a field or skirt:** The right-hand side of the field when looking facing the roof from the eaves
- **Left of a field or skirt:** The left-hand side of the field when looking facing the roof from the eaves
- **Valley:** The line of intersection of two fields of a roof, into which water runs.
- **Hip:** The sloping line created by the intersection of two fields, from which the water is distributed onto these fields.
- **Ridge:** The horizontal line created by the intersection of two fields (gabled roof) or of the intersection of a field with a vertical plane (skillion, lean-to or pent roof)
- **Gable:** Supporting wall delineated by the roof above

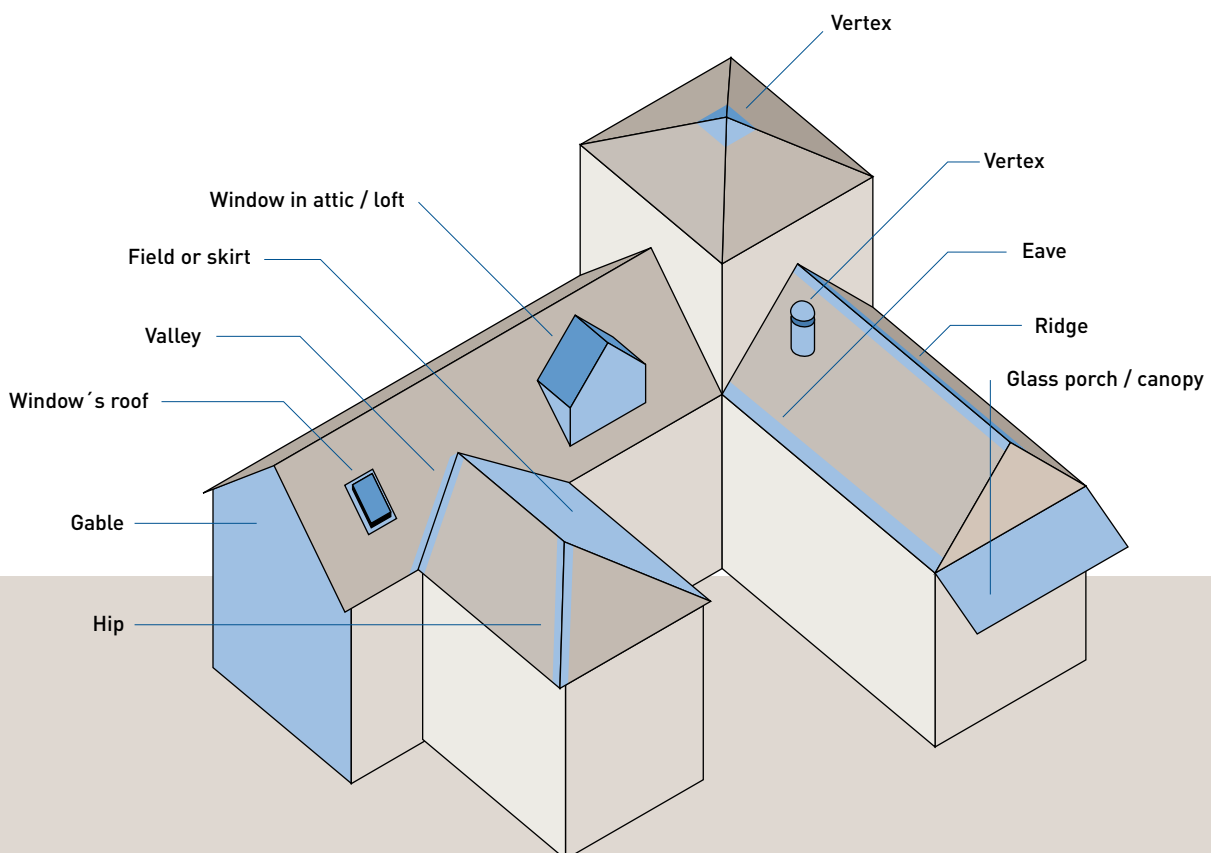

Types of roof support

Continuous frame

The continuous frame or structure must have the required slope, with no more than a 3cm difference from the theoretic slope, in order to ensure the correct laying and fixing of the tiles and to prevent water from getting between the interlocks and overlaps of the tiles.

Types of continuous frame

a) Fibercement sheets

Fibercement panels act as a frame and an impermeable substrate, and can have heat-insulating characteristics. Tiles can be laid directly on the panels, or on battens.

b) Prefabricated concrete

Prefabricated cement frames come in panels and must have adequate dimensional stability and levels of non-deformity, to guarantee they are flat enough for purpose.

c) Concrete foundation /slab

Sloped fields of cement slabs act as a structural foundation. To achieve the level of flatness necessary for the tiles to be laid, apart from careful workmanship and finishing, the slabs must be screed.

d) Ceramic material with a compression layer

The panel is made up of hollow-cavity ceramic pieces and is laid on hollow brick walls that must be correctly aligned and spaced, in order to be subsequently given a finishing layer of cement.

e) Insulation panels

Insulating panels are elements made from an insulating core of expanded or extruded polyurethane, mineral wool, etc., and one or two layers of fibre cement, laminated plaster, wood, sheet metal etc. Laying them is a construction system specific to roofing.

They are dry-laid, at a slope that is adequate for ceramic tiles to be laid using battens.

Discontinuous support

Discontinuous support is made up of a frame of linear elements called battens, which provide a supporting plane to the tiles. The battens must be perfectly aligned and of regular size in both height and width, to provide uniform support.

For Curved Roof Tiles (T5, T40, T4, T45), the battens are generally laid parallel to the maximum slope line of the field. The curved tiles simply rest between two battens. The distance between these must enable a minimum tile overlap of 30mm to guarantee a correct flow of water.

For Mixed Roof Tiles (Large and Small), Flat Roof Tiles (Marseille) and Planum, Visum3, Innova and Vienna roof tiles, the battens are laid perpendicular to the maximum slope line. The tiles are laid and fixed on them. The laying of the battens must take into account the dimensions of the tiles, in order to place them correctly so that the tiles can be correctly laid on them, and interlock perfectly.

Types of Battens

a) self-supporting battens

Self-supporting battens are nailed, screwed or welded to the slats, straps, hollow brick walls, etc., which are similarly fixed to the beams or trusses. Together, they form a supporting lattice.

The battens role is to ensure resistance, stability and durability, to prevent corrosion and deterioration processes. NO warping of more than 5mm is allowed.

b) Metal or Wood Battens fixed ...

In this instance, battens are laid by the discontinuous supports, at least every two metres, to improve ventilation of the underside of the tiles.

Wood battens will be 45mm wide and 35mm high, +/- 5mm tolerance. They are normally made in pine, matured for 6 months, humidity under 8% and treated against fungus and insects.

Standard section of wooden battens

Dimensions of the section	Maximum spacing distance (mm) between support axes depending on charge		
	100 kg/m ²	150 kg/m ²	300 kg/m ²
Width x Height (mm)			
25 x 18	400	350	400
25 x 22	450	430	450
25 x 25	550	500	450
32 x 25	600	540	500
32 x 25	640	570	520
50 x 25	700	600	550
32 x 32	790	700	650
38 x 32	830	740	680
38 x 38	1.000	890	820
50 x 38	1.000	980	900

Calculation of Spacing between Battens

The distance between battens must be calculated based on the tiles that will be used for the roof, thus:

a) Randomly select 12 tiles from several palets on a flat area, set up the tiles properly overlapped, in a longitudinal line ensuring that the tiles are spaced as widely as possible. Measure the length **B** (in cm) between the 2nd and the 12th tile, as shown in the figure below:

b) Next lay a row with the shortest possible spacing between the tiles and, between the same points, measure the minimum longitude **b** (in cm).

c) When the size of the posterior interlock of the tiles is small, the distance between battens (**A**) will be calculated as $A = (B+b) / 20$.

d) The distance must be accurately marked on the two lateral edges of the slope, using a metric rule laid out at its full length following the maximum slope line, that is, perpendicular to the line defined by the eaves. After doing this, use a chalk line stretched between each of the opposite points, placed at the same level between the two extreme sides of the slope, to successively mark up the whole roof. Battens must always, at every level, follow the marked line.

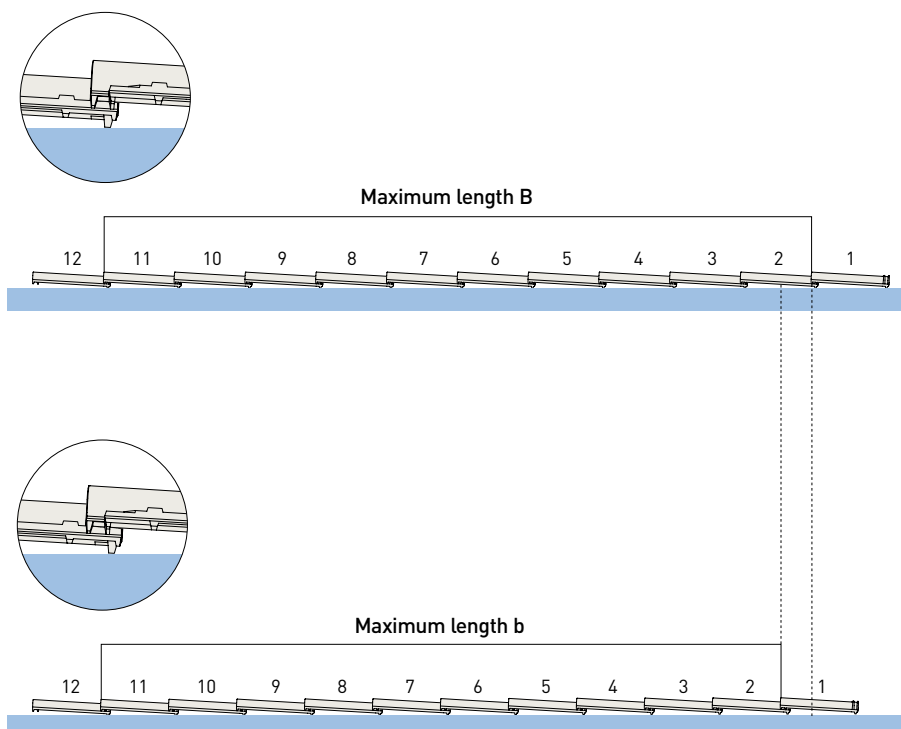



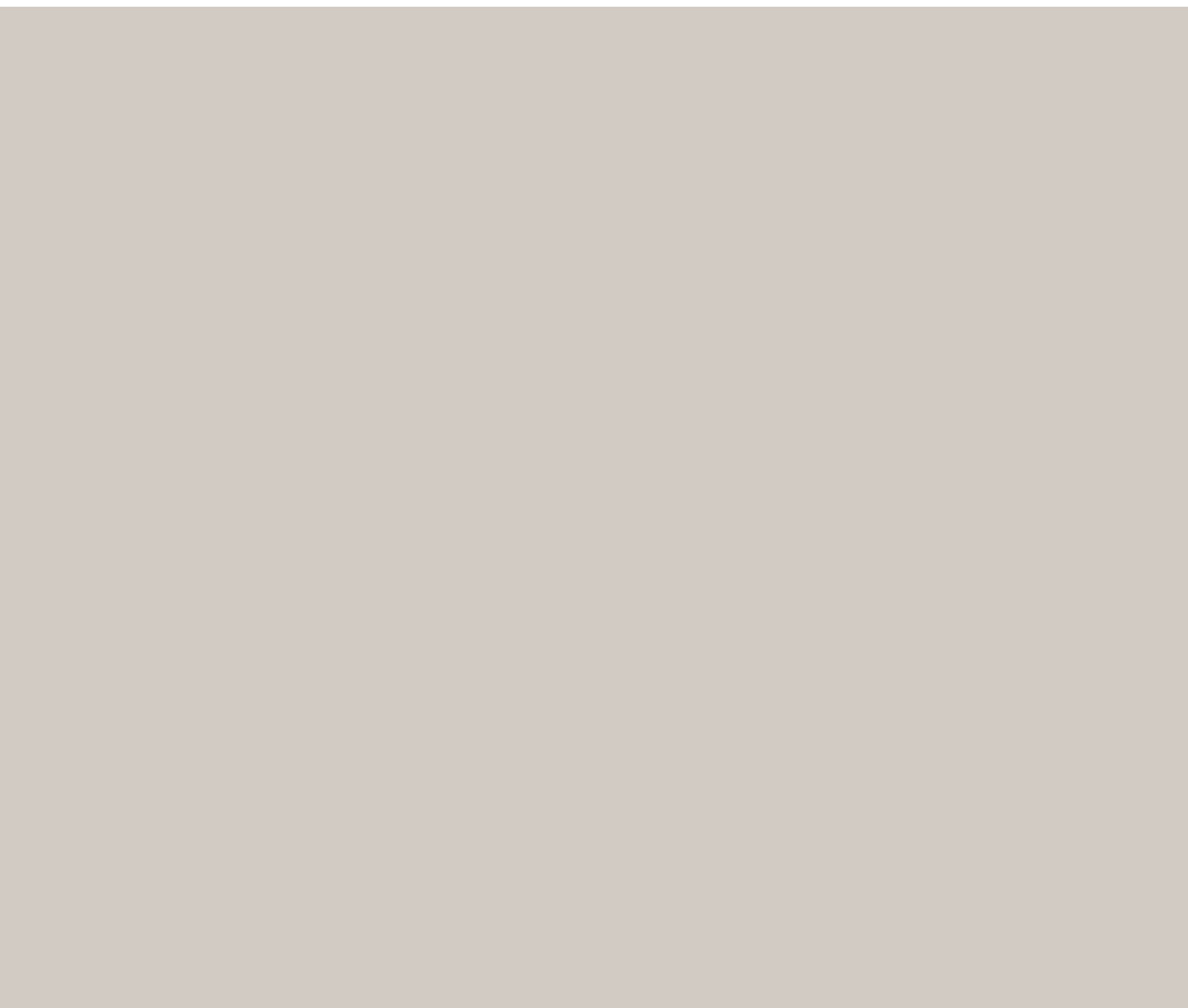

Getting started

03



Getting started



When laying a roof, the following principle factors must be taken into account:

Situation:

- Geographic Area / Housing Location
- Climatic Zones
- Shape of construction
- Type of roofing

Physical Characteristics:

- Type of clay used
- Shapes and designs
- Ribbing, nibs and interlocks

Form of installation:

- Slope of the roof
- Tile laying: linear or broken bond (cross bond)
- Overlap and distance between battens
- Type of batten and their installation method
- Fixation materials for the tiles

Climatic Zones

Exposure zones

When deciding on a roof design, we must take into account factors such as the altitude, the strength of the prevailing winds, rain levels and the frequency of storms. These factors can define three different zones of exposure.

Zone 1: Zones at an altitude below 200m.

Zone 2: Zones at altitudes between 200m and 500m.

Zone 3: Zones above 500m.

NOTE: Over 700m, dry laying. Over 900m (zone 3) refer to Code of Limitations and Installation in High Mountains, provided by The Technical Centre for Natural Construction Materials (CTMNC- France).

Geographical Area / Housing Location

In order to decide on a roof design, we must take into account the geographical location of the house. From that, three different situations can be defined:

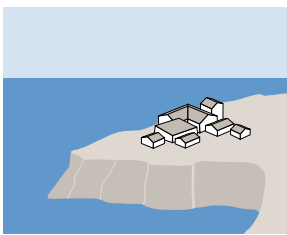

Exposed Locations:

Places open to strong winds, coastal areas (up to 5 km / 3 miles from the shoreline), islands or narrow peninsulas, estuaries or closed bays, narrow valleys, isolated mountains, mountain passes and earthquake zones.

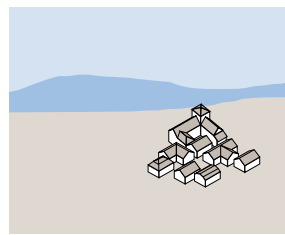
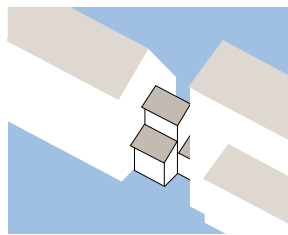

Normal Locations:

Flat area, plateau with minimal elevation changes.

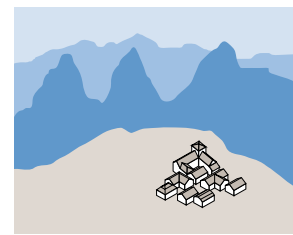

Protected locations:

Hollow area which is surrounded by hills that protect the hollow from the winds in all directions.

Shape of construction

Building shapes used depending on climate

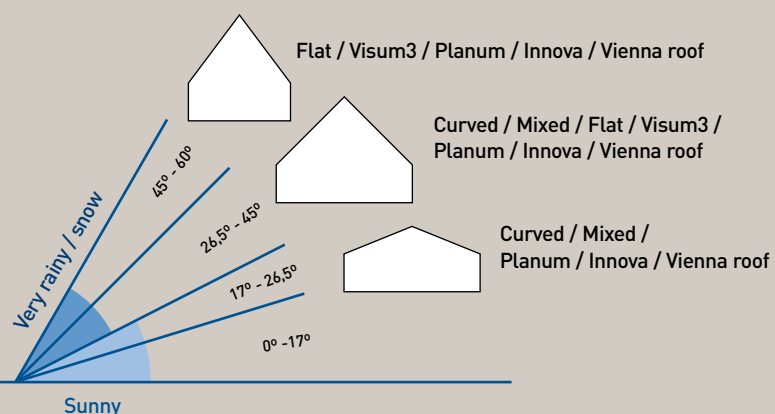

Prior inspection of the field

The real length of the field, indispensable for laying a roof, is calculated by multiplying the ground length of the eaves by coefficient 'K', obtained from the data of the slope or pitch using the following table:

Real length calculation

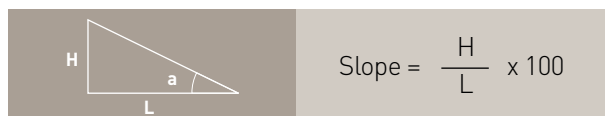

$$\text{Slope} = \frac{H}{L} \times 100$$

Slope (%)	19	20	21	22	23	24	25	26	27	28	29	30
Slope (°)	10°45	11°18	11°51	12°24	12°57	13°29	14°02	14°34	15°06	15°38	16°10	16°41
"K" Coefficient	1,0179	1,0198	1,0218	1,0239	1,0261	1,0284	1,0308	1,0232	1,0358	1,0384	1,0412	1,0440

Slope (%)	31	32	33	34	35	36	37	38	39	40	41	42
Slope (°)	17°13	17°44	18°15	18°46	19°17	19°47	20°18	20°48	21°18	21°48	22°17	22°46
"K" Coefficient	1,0469	1,0499	1,0530	1,0562	1,0595	1,0628	1,0662	1,0697	1,0733	1,0770	1,0808	1,0846

Slope (%)	43	44	45	46	47	48	49	50	51	52	53	54
Slope (°)	23°16	23°44	24°13	24°42	25°10	25°38	26°06	26°33	27°01	27°28	27°55	28°22
"K" Coefficient	1,0885	1,0925	1,0965	1,1007	1,1049	1,1092	1,1135	1,1180	1,1225	1,1271	1,1317	1,1365

Slope (%)	55	56	57	58	59	60	61	62	63	64	65	70
Slope (°)	28°48	29°14	29°40	30°06	30°32	30°57	31°22	31°47	32°12	32°37	33°01	34°59
"K" Coefficient	1,1413	1,1461	1,1510	1,1560	1,1610	1,1661	1,1713	1,1766	1,1819	1,1872	1,1927	1,2206

Slope (%)	75	80	85	90	95	100	105	110	115	120	125	130
Slope (°)	36°52	38°39	40°21	41°59	43°31	45°00	46°40	47°73	48°99	50°19	51°34	52°43
"K" Coefficient	1,2500	1,2806	1,3124	1,3453	1,3793	1,4142	1,4500	1,4866	1,5240	1,5620	1,6008	1,6401

Slope (%)	135	140	145	150	155	160	165	170	175	180	185	190
Slope (°)	53°47	54°46	55°41	56°31	57°17	57°99	58°78	59°53	60°26	60°95	61°61	62°24
"K" Coefficient	1,6800	1,7205	1,7614	1,8028	1,8446	1,8868	1,9294	1,9723	1,0156	1,0591	1,1030	1,1471

Slope (%)	195	200	205	210	215	220	225	230	235	240	245	250
Slope (°)	62°85	63°43	64°00	64°54	65°06	65°56	66°04	66°50	66°95	67°38	67°80	68°20
"K" Coefficient	2,1915	2,2361	2,2809	2,3259	2,3712	2,4166	2,4622	2,5080	2,5539	2,6000	2,6462	2,6926

The installation sections for each of the La Escandella tile types ensures we know how many pieces per square metre of each type is needed to lay the roof correctly.

Slopes / Pitches

The slope is a base parameter in roof design. It ensures the correct evacuation of water, dictates the fastening methods, etc. A steeper slope will ensure a roof dries more quickly in times of heavy rain.

To guarantee correct behaviour of a roof, the recommended minimum slope must be taken into account. These are calculated based on the length of the field and the climatic conditions in the installation location,

as shown in the tables. For slopes that are less steep than recommended, a waterproof membrane will be required in order to ensure the roof remains watertight. For fields greater than 12m long, the whole field must be waterproofed, and an intermediate gutter must be laid, for water evacuation.

CURVED ROOF TILE

ZONE 1

Slope (%)	26	28	30	32	34	36	38	40	42	44	>46
Slope (°)	15	16	17	18	19	20	21	22	23	24	>25
Overlapping (cm)	15,0	14,0	13,5	13,0	12,5	12,0	11,5	11,0	10,0	10,0	7,0

ZONE 2

Slope (%)	26	28	30	32	34	36	38	40	42	44	>46
Slope (°)	15	16	17	18	19	20	21	22	23	24	>25
Overlapping (cm)	*	15	14,5	14,0	13,5	13,0	12,5	12,0	11,0	10,0	7,0

ZONE 3

Slope (%)	26	28	30	32	34	36	38	40	42	44	>46
Slope (°)	15	16	17	18	19	20	21	22	23	24	>25
Overlapping (cm)	*	*	*	15,0	14,5	14,0	13,5	13,0	12,0	11,0	7,0

*Critical situation: a waterproofing underlayment on the entire deck MUST be applied.

Note: for hips LESS than 6.5m long, in normal locations or unfavorable climatic zone, the 32% slope MUST BE APPLIED.

Note: La Escandella warranty will be honored when installation is in strict accordance with local building codes, particularly to those referring to the ventilation of the deck and minimum slope requirements. Clay roof tiles should always be installed in full compliance with the local building codes and good tiling practice. For each country, please refer to local building codes.

MIXED ROOF TILE / INNOVA / VIENNA

Without Underlayment			
	ZONE 1	ZONE 2	ZONE 3
LOCATION	Hip < 6.5m		
Protected	22% / 12°	24% / 13°	27% / 15°
Normal	25% / 14°	27% / 15°	30% / 17°
Exposed	33% / 18°	37% / 20°	40% / 22°
	Hip 6.5m to 9.5m		
Protected	26% / 14°	28% / 15°	30% / 17°
Normal	28% / 15°	32% / 17°	36% / 19°
Exposed	35% / 19°	39% / 21°	43% / 23°
	Hip 9.5m to 12m		
Protected	27% / 15°	30% / 17°	35% / 19°
Normal	32% / 17°	35% / 19°	40% / 22°
Exposed	42% / 22°	45% / 24°	50% / 26°

With Underlayment*			
	ZONE 1	ZONE 2	ZONE 3
LOCATION	Hip < 6.5m		
Protected	19% / 10°	21% / 11°	25% / 14°
Normal	21% / 11°	23% / 12°	28% / 15°
Exposed	28% / 15°	32% / 17°	38% / 20°
	Hip 6.5m to 9.5m		
Protected	22% / 12°	24% / 13°	30% / 17°
Normal	24% / 13°	27% / 15°	30% / 17°
Exposed	30% / 17°	33% / 18°	42% / 22°
	Hip 9.5m to 12m		
Protected	23% / 12°	26% / 14°	30% / 17°
Normal	27% / 15°	30% / 17°	35% / 19°
Exposed	36% / 19°	39% / 21°	45% / 24°

FLAT ROOF TILE

Without Underlayment			
	< 6,5m	6,5m - 9,5m	9,5m - 12m
Gables			
Protected	35% / 19°	35% / 19°	50% / 26°
Normal	40% / 22°	50% / 26°	60% / 30°
Exposed	60% / 30°	70% / 34°	80% / 38°

With Underlayment*			
	< 6,5m	6,5m - 9,5m	9,5m - 12m
Gables			
Protected	30% / 17°	30% / 17°	45% / 24°
Normal	35% / 19°	45% / 24°	50% / 26°
Exposed	50% / 26°	60% / 30°	70% / 34°

PLANUM / VISUM3

Without Underlayment			
	< 6,5m	6,5m - 9,5m	9,5m - 12m
Gables			
Protected	45% / 24°	50% / 26°	55% / 28°
Normal	50% / 26°	55% / 28°	65% / 33°
Exposed	65% / 33°	75% / 36°	85% / 40°

With Underlayment*			
	< 6,5m	6,5m - 9,5m	9,5m - 12m
Gables			
Protected	40% / 22°	45% / 24°	45% / 24°
Normal	45% / 24°	45% / 24°	55% / 28°
Exposed	60% / 30°	65% / 33°	75% / 36°

*Waterproof membrane: minimum weight 135 gr/m².

Note: La Escandella warranty will be honored when installation is in strict accordance with local building codes, particularly to those referring to the ventilation of the deck and minimum slope requirements. Clay roof tiles should always be installed in full compliance with the local building codes and good tiling practice. For each country, please refer to local building codes.

The slopes given in that document are those that La Escandella recommends, based on our experience and based on the French standards [DTU 40.21: NF P31-202-1 Couvertures en tuiles de terre cuite à emboîtement ou à glissement à relief // DTU 40.211: NF P31-203-1 Couvertures en tuiles de terre cuite à emboîtement à pureau plat] and their DTA, Document Technique d'Application- 5/14-2389, technical guide for laying shallow slopes with Large Mixed tiles, and for Small Mixed tiles, 5/15-2459].

Fixing methods and components required

The manner in which roof tiles are installed makes them a highly effective water shedding assembly that affords years of service and protection. The effectiveness of a tile roof system as a weather resistant assembly however depends on the proper installation of all the tile roof components, and installing them properly is critical to the performance of the installed system.

Fastening methods for curved roof tile

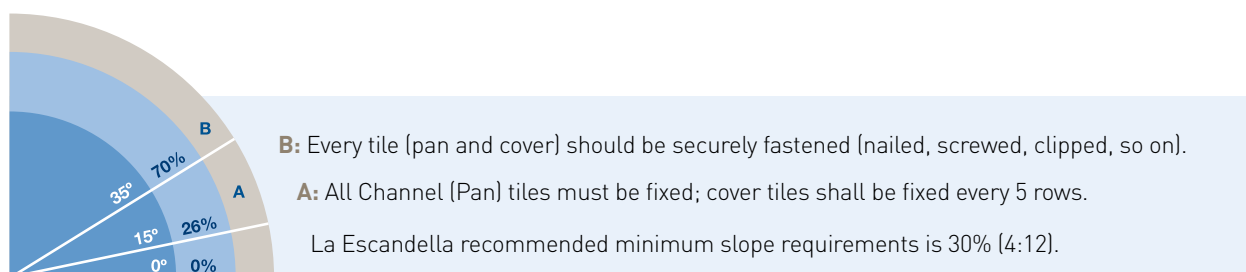

Fixing methods for interlocking tiles and flat tiles

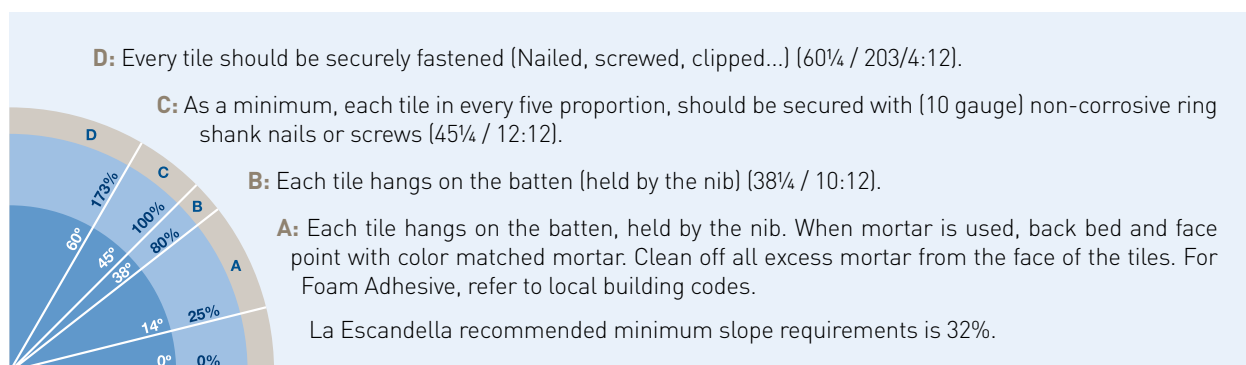

Fixing Components for Tiles

The function of fixing components is to provide the join between the tiles and any accessories, and the support, in order to prevent them from moving.

- Metal-plate screw
- Self-drilling screw
- Stainless steel hook
- Steel rod
- Steel plate
- Hip and Ridge tile fixing clips
- Hip and Ridge tile fixing screws
- Polyurethane foam
- Glue and adhesives



Note: The locking function is performed by the metal clamps / hooks. Polyurethane foam acts only as a positioner. Any fastening done with screws, nails, clips etc., must be sealed in order to prevent water entering. All fasteners must be non-corroding.

Ventilation and waterproofing

Ventilation is one of key elements to assure a good hygrothermal behavior of the roof and preservation of the roof structure. The key to a good and well preserved roof is a good ventilated roof. Proper installation of Ventilation tiles combined with ventilated roof can result in energy savings, in a more energy efficient home.

Air should be able to flow through the eave and ridge; be sure not to close these off with cement, mortar or similar. Eave and ridge areas should be protected to help minimize the access of birds and vermin infiltration.

Air will enter through the lower part of the roof, through the eaves or valleys, and will exit through the upper part of the roof, through the ridge and hips. Roof ridge ventilating roll (Alu-Roll) or sealing ventilation tape can be used, or each piece can simply be fixed to the ridge.

The interior circulation length must not exceed 12m, rising from the eaves to the ridge. A minimum air circulation gap of 20-40mm between the lower face of the tile and the support/insulation will be left. For fields greater than 12m, the air passage must be a minimum of 60mm.

Additionally, if you are laying a roof with battens, a 20-30mm gap must be left between them every 2 metres, to guarantee air circulation.

A greater difference in height between the entry and exit provides better ventilation.

La Escandella offers a wide selection of Accessories designed for each of the different tile models (the Mixta, the Curva, the Plana, the Planun and the Visum3) which will ensure roofs are both functional and aesthetic.

- **Ventilating ridge band**, Alu-Roll. As well as supporting the caps, ventilating ridge band allows the air from the micro-ventilation to exit via the ridge.

- **Ventilation Tiles** correctly for each model and type of tile. The ventilation tile will be placed so that it is staggered with respect to the entry tiles, and never in the row next to the ridge.

- **Comb eaves filler**, which, as well as ensuring the vertical alignment for the first row of tiles, helps micro-ventilation by allowing air to pass.

- **Bird stopper**. This ensures the roof is ventilated through the eaves, and at the same time it provides protection against insects and small creatures.

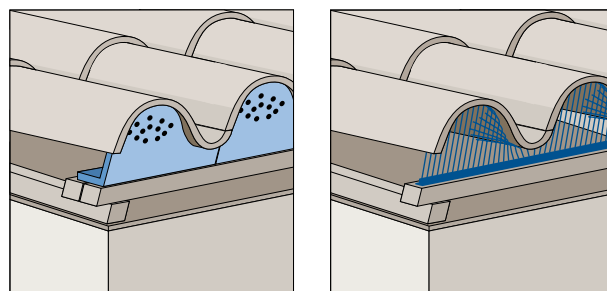

Bird stopper

Eaves ventilation comb

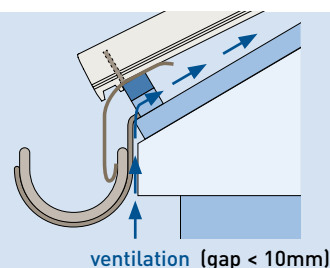
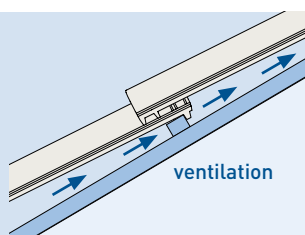
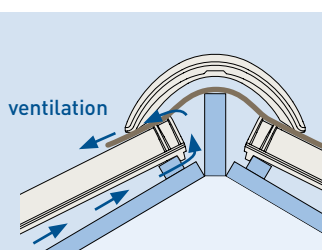



Note: For slopes of less than 25°, the length of a field may not be greater than half of the number of degrees of the slope. E.g., for a slope of 25°, the maximum field length is 12.5m. For slopes of less than 25°, there is no limit to field ventilation.

Note: La Escandella product guarantee is conditional on correct use of the products, in particular that they are laid with at least the minimum slope and with adequate ventilation. In Spain, refer to UNE 136020 for the full criteria, and in other countries refer to the current building regulations.

Furthermore, there must always be a space between the supporting frame and the tiles, which will allow air to circulate under them and micro-ventilation. Additionally, a ventilation tile must be laid every 7m² and at minimum two per field.

Depending on the type of tile used, the following accessories will be needed:

					
Q22-Q23 Curved* ¹ Ventilation Tile	Q19-Q20 Mixed Ventilation Tile	Q21 Flat Ventilation Tile	Q86 Planum Ventilation Tile	Q96 Visum3 Ventilation Tile	Q117 Innova / Vienna Ventilation Tile
Airflow section: Q22: 24,6 - Q23: 27,8 cm ²	Airflow section: Q19: 17,5 - Q20: 4,3 cm ²	Airflow section: Q21: 3,4 cm ²	Airflow section: Q86: 18,9 cm ²	Airflow section: Q96: 16,7 cm ²	Airflow section: Q117: 20,2 cm ²

These ventilation accessories will prevent there being an excessive temperature difference between the underside of the tiles and the upper side of the support, which could initially create humidity problems through condensation, and could later cause cracking in areas subject to frost.

To ensure correct ventilation, the interior air circulation must not be blocked by any intermediary component, and the circulation flow length must not exceed 12m. The air should circulate from the eaves to the ridge.

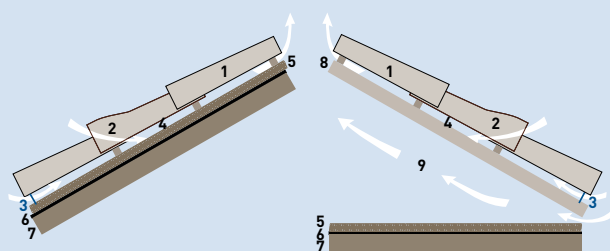
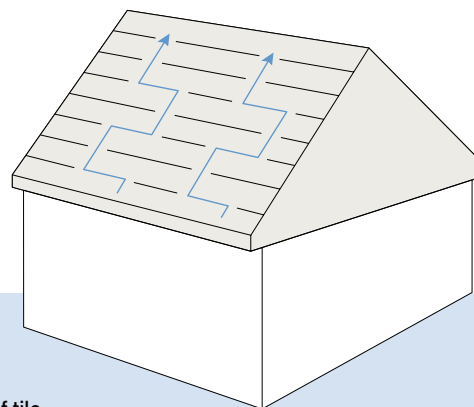

1. Roof tile
2. Ventilation roof tile *2
3. Eaves ventilation comb
4. Micro-ventilation void
5. Heat insulation underlayment
6. Waterproof underlayment material
7. Frame
8. Rafter
9. Attic

*1Note: Where Curved Tiles have been placed on corrugated sheeting, refer to the sheeting manufacturer's manual.

*2Note: The ventilation tile will be offset to free the air entry, and must never be laid in the row next to the ridge.

Benefits of a ventilated roof

• Quality of Life:

High levels of humidity in the atmosphere can trigger or aggravate certain health problems.

• Saving Energy

Ventilated roofs can provide energy savings of 20 to 30%. What is more, a damp house takes much longer to warm up, increasing the heating bill by as much as 25%.

• Noise protection

• Humidity protection

Damp gradually damages your home, and can even lead to its demolition. Lack of ventilation in a roof can lead to problems of humidity through condensation and could later cause cracked tiles in areas subject to frost.



Humidity problems due to poor ventilation.

Thermal insulation and Waterproofing

The roof of a building is very exposed to severe weather conditions, and so it must be built to ensure it is completely waterproof.

Some options:

- **Asphalt tiles.** Ideal for flat roofs.
- **EPDM rubber sheets.** For all roof types
- **Liquid polyurethane membranes.** For roofs with a lot of installations, skylights etc.
- **Multilayer polypropylene sheets.** For sloping roofs (under-tile waterproofing).
- **Bitumen boards.** For sloping roofs (under-tile waterproofing)

SUSTAINABILITY FACTS



“Insulating the roof, as well as waterproofing, can provide savings of as much as 900€/year (£650-£700) and reduces CO₂ emissions by 200kg/year (a dwelling of 80m² or around 260 sq ft). In this case, roof insulation pays for itself in less than two years”

Waterproof Membranes

Waterproof underlay is a flexible, impermeable sheet whose main function is to protect the roof. The layers breathe, so dissipating moisture outside and at the same time preventing water from entering inside, should there be any fault in the protecting cover.

The high ventilation capacity provided by these membranes, together with correctly laid tiles to ensure micro-ventilation, ensures proper ventilation and elimination of interior humidity and **prevents condensation, which has a detrimental effect on the structural materials of the roof, especially when it has a continuous or discontinuous wooden frame.**

This breathing layer is laid on sloping roofs using mechanical fixings. A ventilation layer should be allowed for in the lower part of the ridge if necessary. A space of at least 2.5cm should be left between the membrane and the tiles.

Although the product is not water-permeable without pressure, it should not be left without a covering for a prolonged period once it has been laid. It is worth noting that waterproof membranes, depending on their type, come in different weights, which makes them more or less water-resistant (higher weight, higher water-resistance).



The waterproof membrane should ideally be laid perpendicular to the maximum slope line, with overlaps of at least 15cm if the slope is greater than 30%, and at least 20cm for lesser gradients.



The battens laid on the waterproof membrane are nailed to the surface or onto the supporting slats. The finishing studs are fixed on the battens.

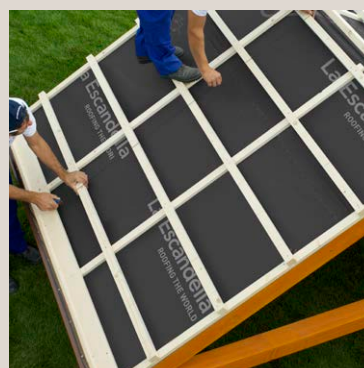

To achieve a perfect microventilation of the roof, we shall place horizontal battens on the vertical ones which we have already placed.

The main advantages of waterproof membranes are:

- **Impermeability to water** (protects from accidental water infiltration and from condensation and channels the waters to the gutters)
- Better thermal efficiency of the roof, so **improved insulation**
- **Protects against infiltration of fine sand**, dust, pollen, snow flakes etc.
- Construction of **sloped roofs with minimum slopes**
- **Protects against the entry of birds**, insects and small rodents
- Assists in **roof ventilation** (enables continuous evacuation of water vapour)
- Improves the **roof's behaviour in windy conditions** by reducing the pressure level under the tiles

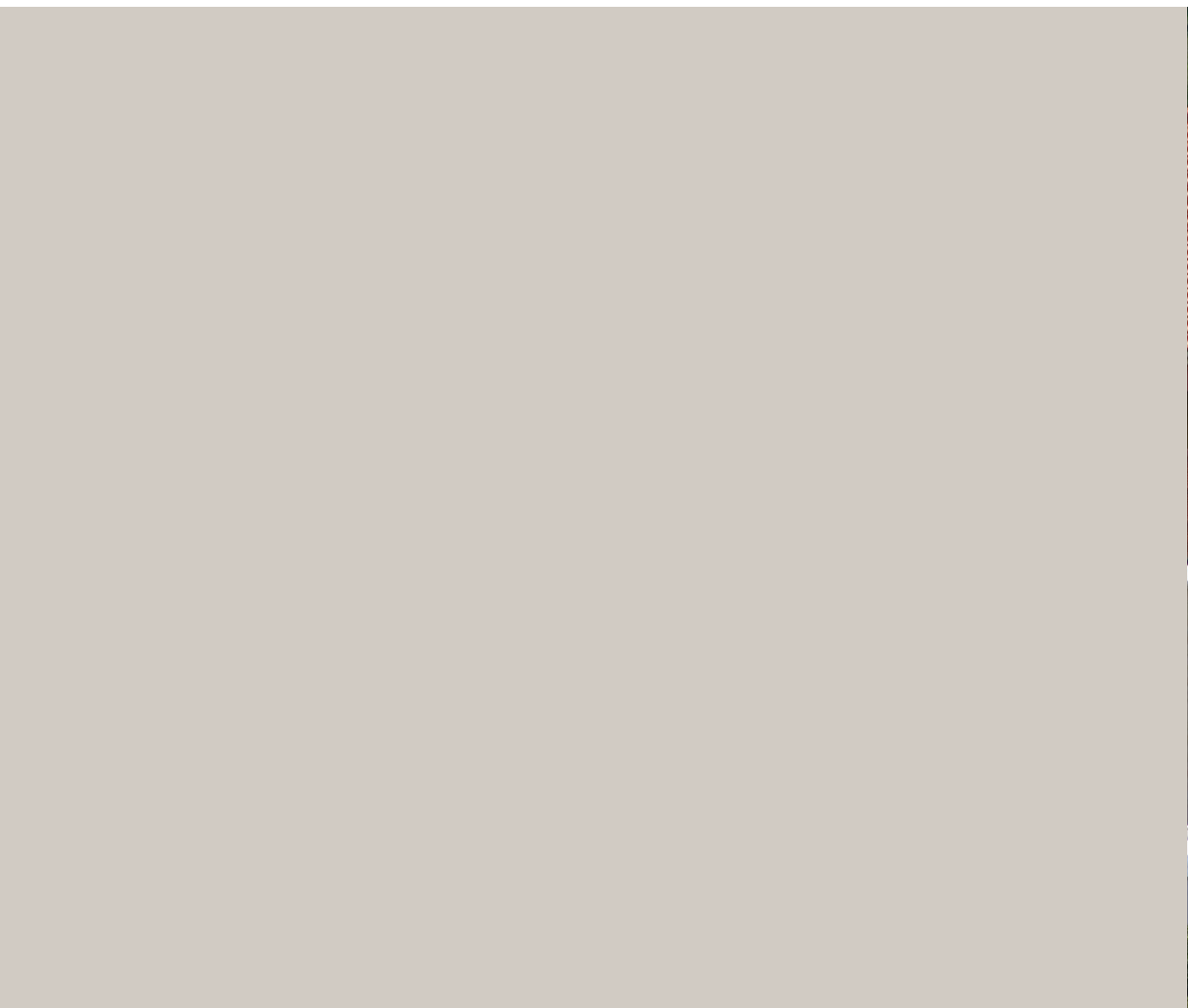

Installation by tile type

Once the geographical situation of the house, the roof slope and size of the field are known, it is time to start calculating the number of tiles needed for that field area, and how it is to be laid, which will depend on the type of roof we are installing.

The calculated field area will be multiplied by the number of pieces per square metre, based on the type of tile we are using.

A further 5% is added to the final number of pieces, since we take into consideration possible losses through cutting, to make adjustments for ridges, hips and valleys.



Interlocking Tiles

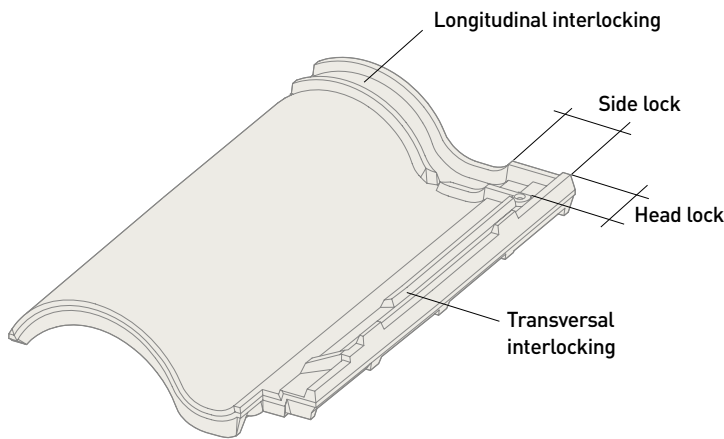

Interlocking or mechanical tiles have a longitudinal or transversal interlocking system, which may be single or multiple. With these systems, laid tiles create a seal between pieces, in both the vertical and horizontal courses.

The interlocking system reduces the likelihood of tile slippage and its purpose is to prevent the passage of water. The longitudinal and/or transversal interlocking of the pieces facilitates the assembling of tiles in horizontal or vertical rows, respectively.

On their underside and along their upper edge, the tiles have one or more flanges or nibs which allow them to be hooked onto the support.

TRANSVERSAL FIT

LONGITUDINAL FIT

MIXED ROOF TILE

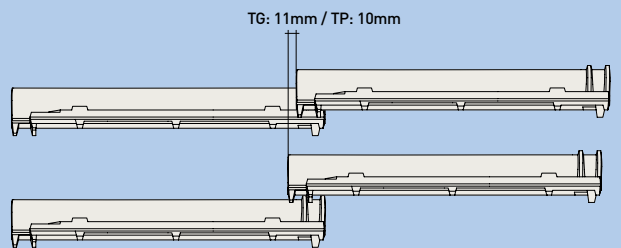
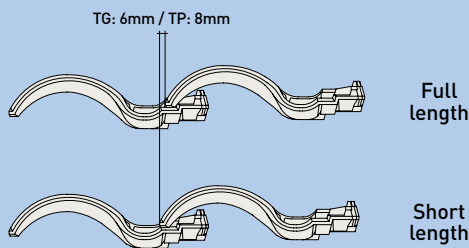

FLAT ROOF TILE

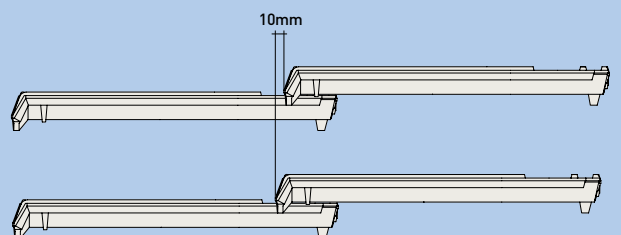
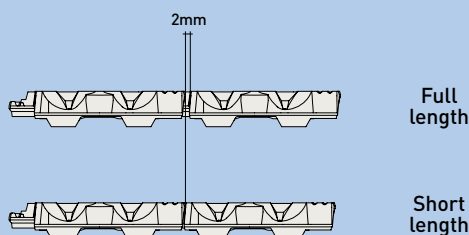

Fitting of longitudinal and transversal interlocks

Mechanical tiles do not have a fixed interlock system, the interlocks are variable, allowing the installer to reset the tiling in the other direction without any cutting.

TRANSVERSAL FIT

LONGITUDINAL FIT

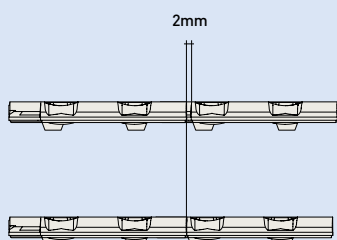

Full length

Short length

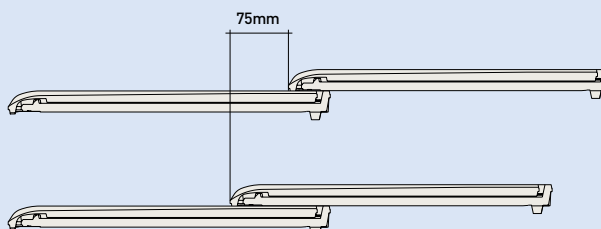

INNOVA

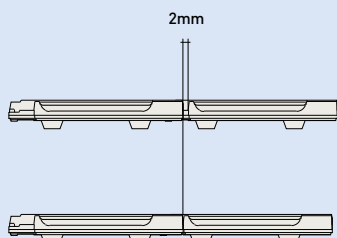

Full length

Short length

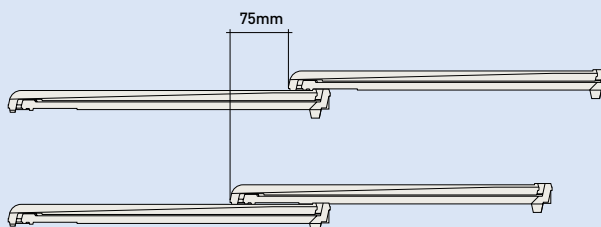

VIENNA

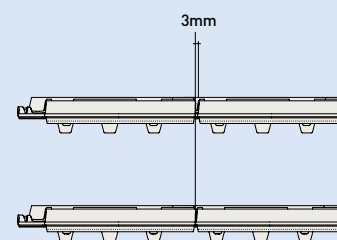

Full length

Short length

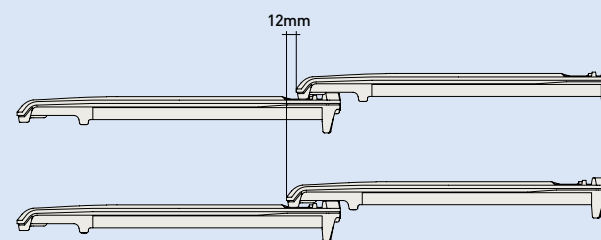

PLANUM

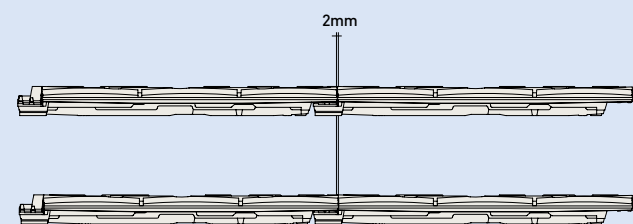

Full length

Short length

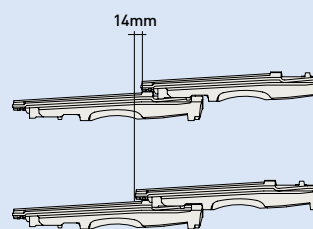

VISUM3

Note: The measurements shown are indicative. La Escandella reserves the right to change any of these dimensions without prior notice. For more information, contact your representative or Customer Service.

Mixed "S" Roof Tile Large (TG) / Small (TP)

Double curvature

Its double curvature, eave and ridge joints design and functionality as Arab roofs looking. Mediterranean aesthetics with the easiest fixation

Wide range of colors

A roof tile with a wide range of colors and complements to satisfy all professionals' needs and preferences; suitable to all type of roofs (new and aged ones)

Double interlocking

The double interlocking -horizontal and vertical- allows the roof to be more watertight, ensuring its impermeability

Higher Resistance

The clay's composition and its perfect press performance make flexion rates even higher than Standard

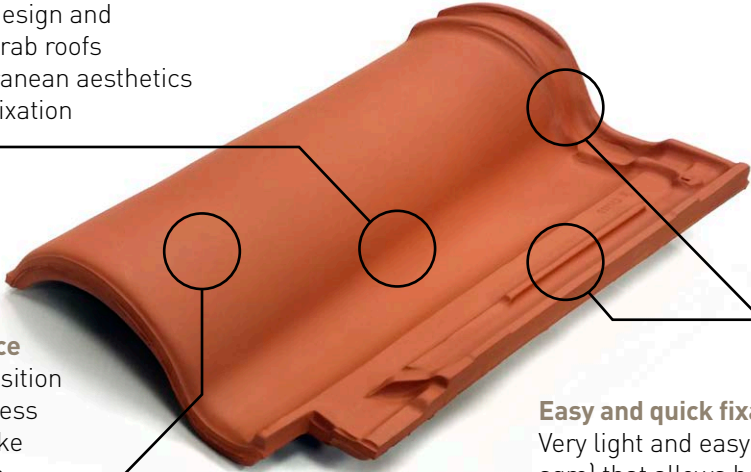

Easy and quick fixation

Very light and easy-to-use roof tile (10.5 pcs/sqm) that allows both lateral and longitudinal tolerances, therefore achieving great stability



*Large mixed roof tile complies with ICC and Miami Dade certifications

	TG	TP
Dimensions*	a: 470 mm b: 286 mm c: 75 mm	a: 441 mm b: 263 mm c: 73 mm
Pieces per m²	10,5	12,5
Weight piece	3.850 gr	3.400 gr
Longitudinal fit**	400 mm (+3;-8mm)	370 mm (±5 mm)
Transversal fit**	230 mm (±3 mm)	203 mm (±4 mm)

	Application Standard	Requirements	MIXED S
Flexural Strength test	EN 538	Resistance > 1200N	Above
Impermeability	EN 539-1	Complies with level 1	Above
Frost Resistance	EN 539-2	Complies 150 cycles	Above
Geometric Characteristics	EN 1024	Flatness ≤ 1,5% Straightness ≤ 1,5%	Complies Complies

*The Tile dimensions indicated in this chart, allow a tolerance of approximately 2%.
**Theoretic value: this should be re-calculated on site with the tiles that are to be used.

Laid method

Laying the roof

1. Installation will begin with La Escandella Mixed "S" left side courses (rakes) from the eave to the ridge, allowing a 5 cm (2") overhang at the eave. All side course (rake) tiles shall be installed with fasteners typical of the field tile installations.

2. The starter course will begin with a full tile from the eave to the ridge, allowing a 5cm (2") overhang at the eave. The tiles structuring the eave will have to overlap the side course (rake) and fit together one to another. The second course of the tile will lay up directly over the previously installed field tile to the proper exposure and overlapping.

3. See (fig.1) for sequence of installation for fist and succeeding courses of tiles from the eave to the ridge.

NOTE: A control line between 3 and 5 rows of tiles (maximum) is recommended.

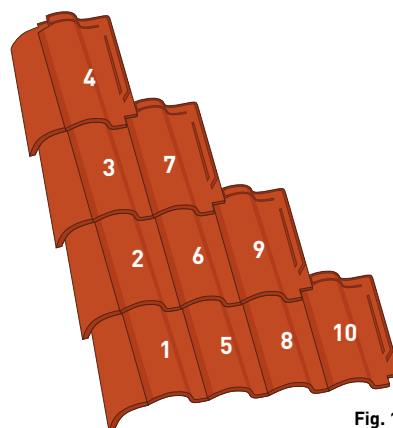
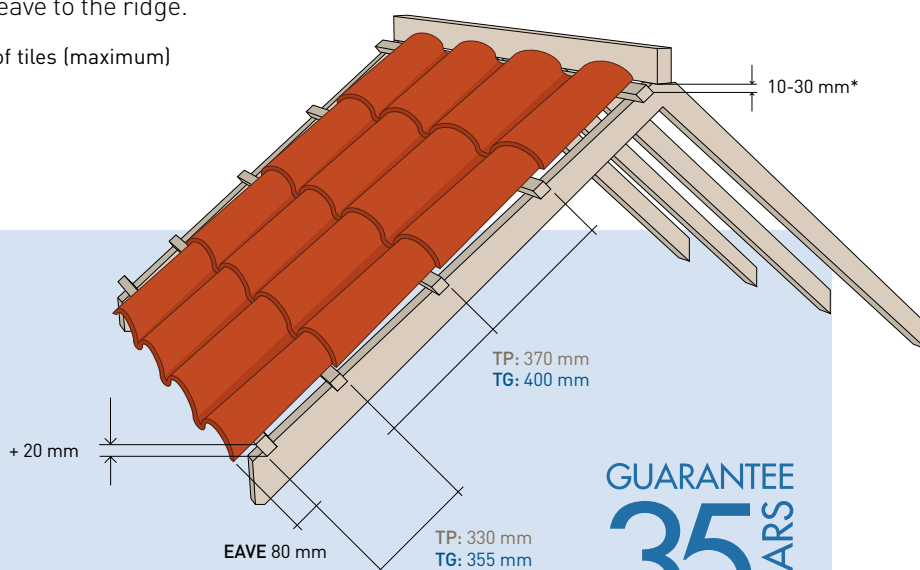

Fig. 1



GUARANTEE
35
YEARS

First course batten should be 20 mm (3/4") higher than all succeeding course battens to provide a vertical alignment and to assure a symmetrical installation

*Depending on the slope. See pages 56-57 – Ridge Section.

Use of half or double tile

The right section (vertical terminating end) of the roof can be finished by using either a Half (1/2) Tile (**Q16-Q17**) (fig.2) or a Double Tile (**Q33-Q34**) (fig.3).

- Mixed "S" roof tile
- **Q10** Straight left side course
- **Q11** Straight right side course
- **Q16 (TG) - Q17 (TP)** Half Mixed "S" roof tile
- **Q33 (TG) - Q34 (TP)** Double Mixed "S" roof tile

Half Mixed "S" roof tile laying

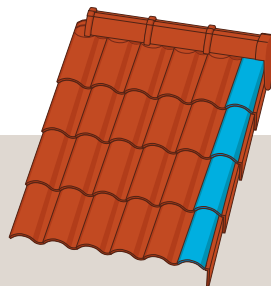
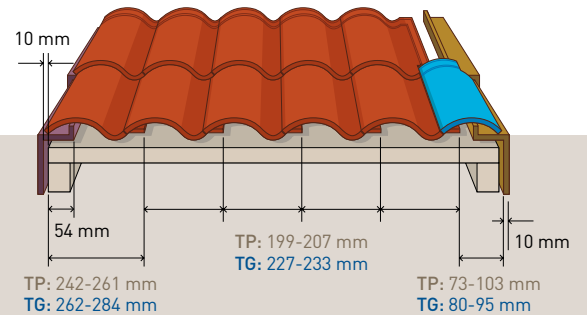

Fig. 2



When installing with half tiles, an additional vertical batten must be added to fix them.

Double Mixed "S" roof tile laying

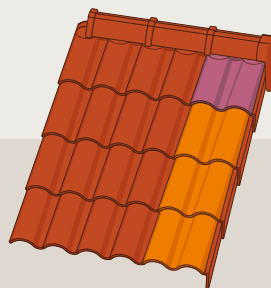
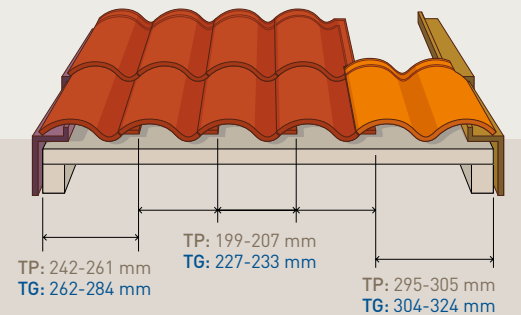

Fig. 3





Flat Roof Tile -Marseille -Alicantina (TL)

Double interlocking

The double interlocking -horizontal and vertical- allows the roof to be more watertight, ensuring its impermeability

Cost reduction

Its large format (11units/m²) and strapping every 5 units, as well as its packaging on pallets of 180 and 240 units, reduce installation costs

Easy and quick fixation

Its traditional shape together with its installation by crossbond, allows a great adaptation to restoration

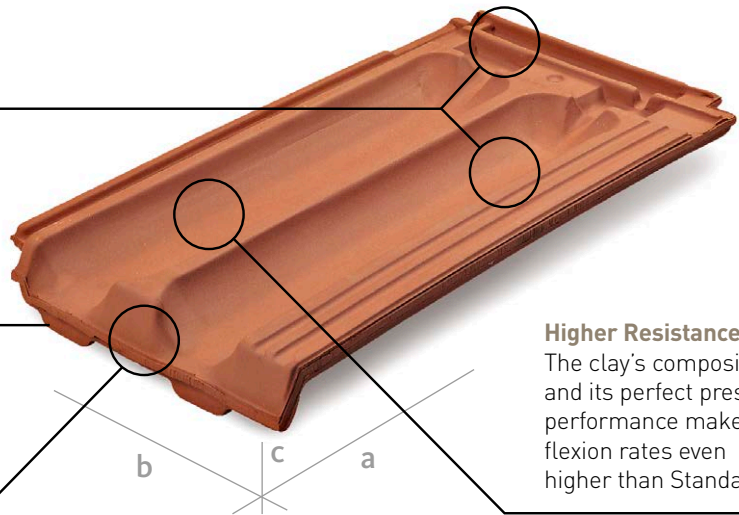

Higher Resistance

The clay's composition and its perfect press performance make flexion rates even higher than Standard

GUARANTEE
35
YEARS



Test of frost resistance



Impermeability test



Flexural strength test



Geometric characteristics

Dimensions*	a: 466 mm; b: 260 mm; c: 55 mm
Pieces per m ²	11
Weight piece	3.600 gr
Longitudinal fit**	403 mm (±5 mm)
Transversal fit**	225 mm (±1 mm)
Laid method	Straight bond pattern Cross bond pattern

	Application Standard	Requirements	FLAT Roof Tile
Flexural Strength test	EN 538	Resistance > 1200N	Above
Impermeability	EN 539-1	Complies with level 1	Above
Frost Resistance	EN 539-2	Complies 150 cycles	Above
Geometric Characteristics	EN 1024	Flatness ≤ 1,5% Straightness ≤ 1,5%	Complies Complies

*The Tile dimensions indicated in this chart, allow a tolerance of approximately 2%.

**Theoretic value: this should be re-calculated on site with the tiles that are to be used.

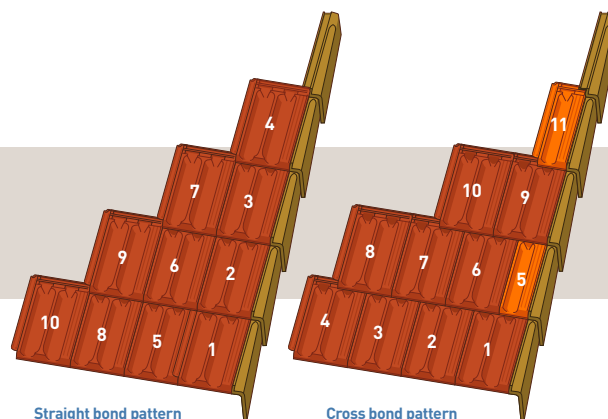

Laid method

Laying the roof

Straight bond pattern:

1. The starter course will begin with a full tile from the eave to the ridge, (allowing a 3.15" (8cm) overhang at the eave).
2. The tiles structuring the eave will have to overlap the side course (rake) and fit together one to another.
3. The second course of the tile will lay up directly over the previously installed field tile to the proper exposure and overlapping. See Figure for sequence of installation for fist and succeeding courses of tiles from the eave to the ridge.
4. The left section (vertical terminating end) of the roof can be closed by using a half (1/2) tile (end band) -Q18 to overlap the left side course (rake) -Q14.

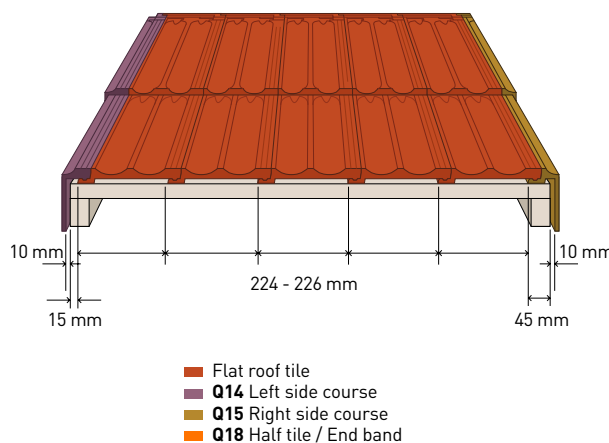

Cross bond pattern:

1. The starter course will begin with a full tile from the eave to the ridge, (allowing a 3.15" (8cm) overhang at the eave). The tiles structuring the eave will have to overlap the side course (rake) and fit together one to another.
2. The second course will be started with half (1/2) tile (end band) -Q18 and will be laid to provide the proper vertical exposure.
3. All joints of the second course and succeeding courses should be at the center line of the previous course, alternating half tiles and full tile at the start and at the end of each course. This is continued through each successive course.

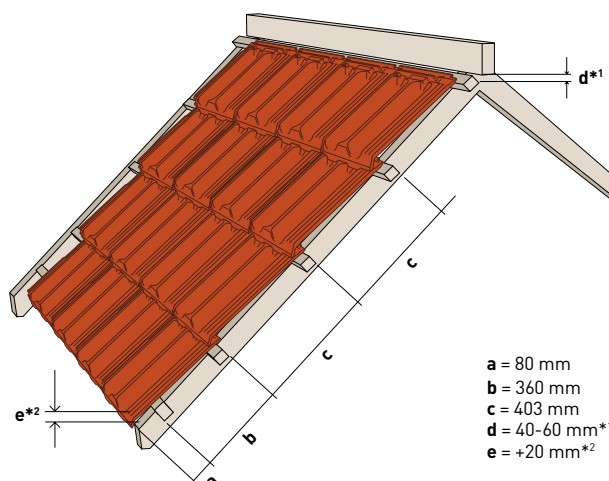
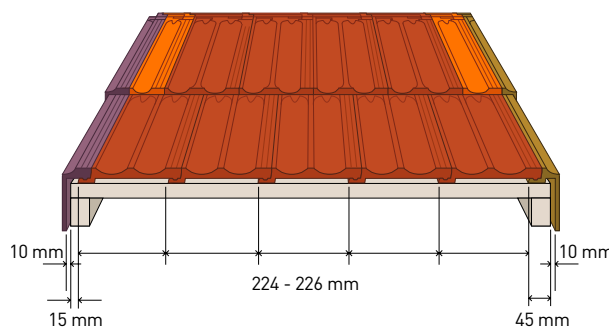

NOTE: A control line between 3 and 5 rows of tiles (maximum) is recommended.

*1Depending on the slope. See page 64 ridge section.

*2First course batten should be 20 mm (3/4") higher than all succeeding course battens to provide a vertical alignment and to assure a symmetrical installation

TG-TP / TL

Accessories



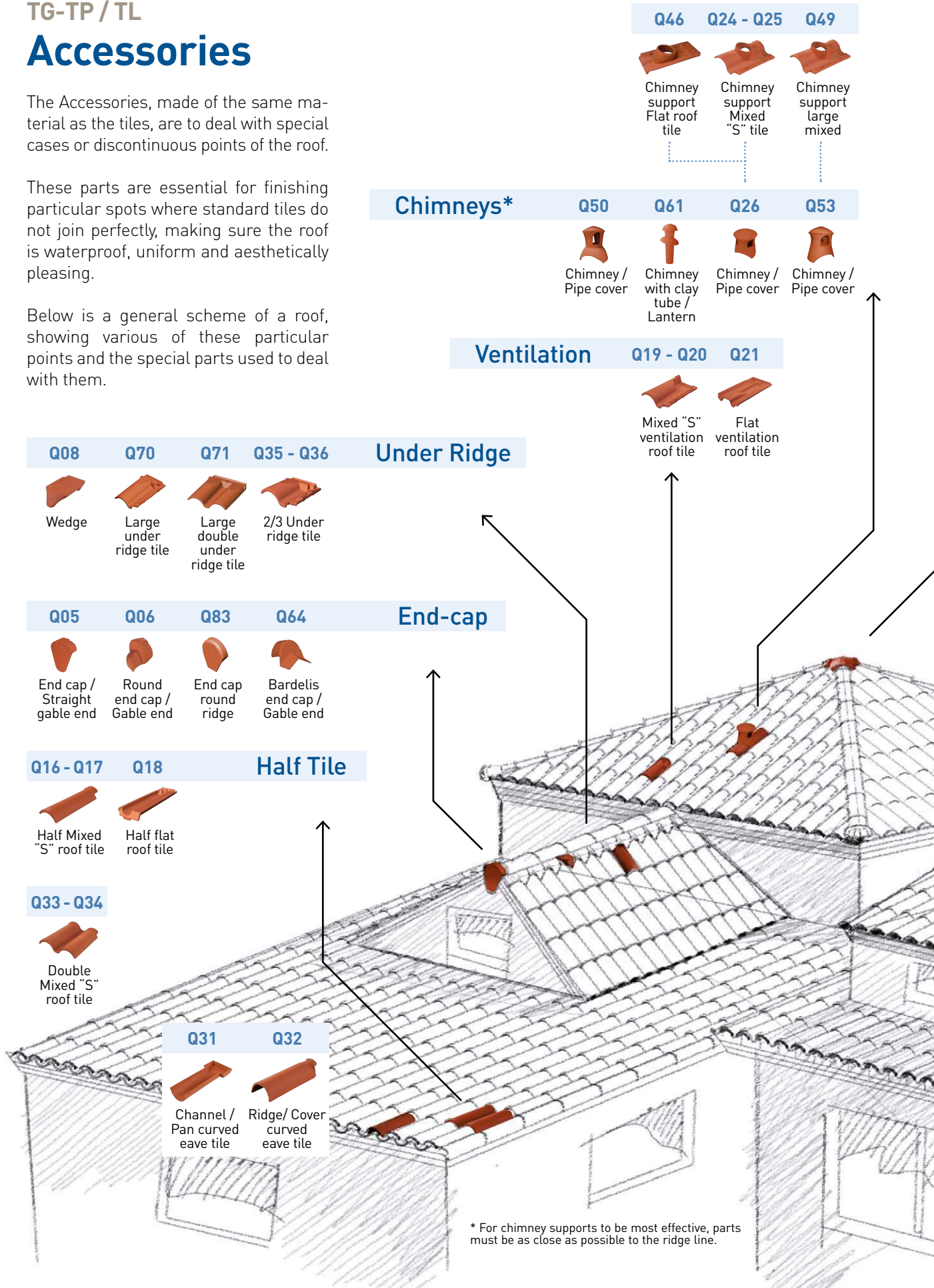

The Accessories, made of the same material as the tiles, are to deal with special cases or discontinuous points of the roof.

These parts are essential for finishing particular spots where standard tiles do not join perfectly, making sure the roof is waterproof, uniform and aesthetically pleasing.





Below is a general scheme of a roof, showing various of these particular points and the special parts used to deal with them.





Q08 Q70 Q71 Q35 - Q36 Under Ridge

- 
 Wedge
- 
 Large under ridge tile
- 
 Large double under ridge tile
- 
 2/3 Under ridge tile

Q05 Q06 Q83 Q64 End-cap

- 
 End cap / Straight gable end
- 
 Round end cap / Gable end
- 
 End cap round ridge
- 
 Bardelis end cap / Gable end



Q16 - Q17 Q18 Half Tile

- 
 Half Mixed "S" roof tile
- 
 Half flat roof tile

Q33 - Q34

- 
 Double Mixed "S" roof tile





Q31 Q32

- 
 Channel / Pan curved eave tile
- 
 Ridge / Cover curved eave tile



Q46 Q24 - Q25 Q49

- 
 Chimney support Flat roof tile
- 
 Chimney support Mixed "S" tile
- 
 Chimney support large mixed

Chimneys* Q50 Q61 Q26 Q53







- 
 Chimney / Pipe cover
- 
 Chimney with clay tube / Lantern
- 
 Chimney / Pipe cover
- 
 Chimney / Pipe cover

Ventilation Q19 - Q20 Q21





- 
 Mixed "S" ventilation roof tile
- 
 Flat ventilation roof tile

* For chimney supports to be most effective, parts must be as close as possible to the ridge line.



Joins

Q07	Q42	Q60	Q30	Q44	Q45	Q55
						
3 way ridge (same slope)	3 way ridge female with slope	3 Way ridge with slope	4 way ridge	Round 3 way ridge	Round 4 way ridge	Round 3 way ridge female









Ridges

Q01	Q02	Q65	Q82
			
Ridge / Hip	Round ridge / Hip	Two way female ridge	Two way male ridge



Ridge end / hip starter

Q03	Q04
	
Ridge end / Hip starter	Round ridge end / Hip starter

Side courses

Q09	Q10	Q12	Q62	Q14
				
Universal side course / Rake	Straight left side course / Rake	Round left side course / Rake	Bardelis left side course / Rake	Left side course for flat roof tile
	Q11	Q13	Q63	Q15
				
	right side	right side	right side	right side

Decorations

Q57	Q28	Q29
		
Acorn	Small piruli	Large piruli

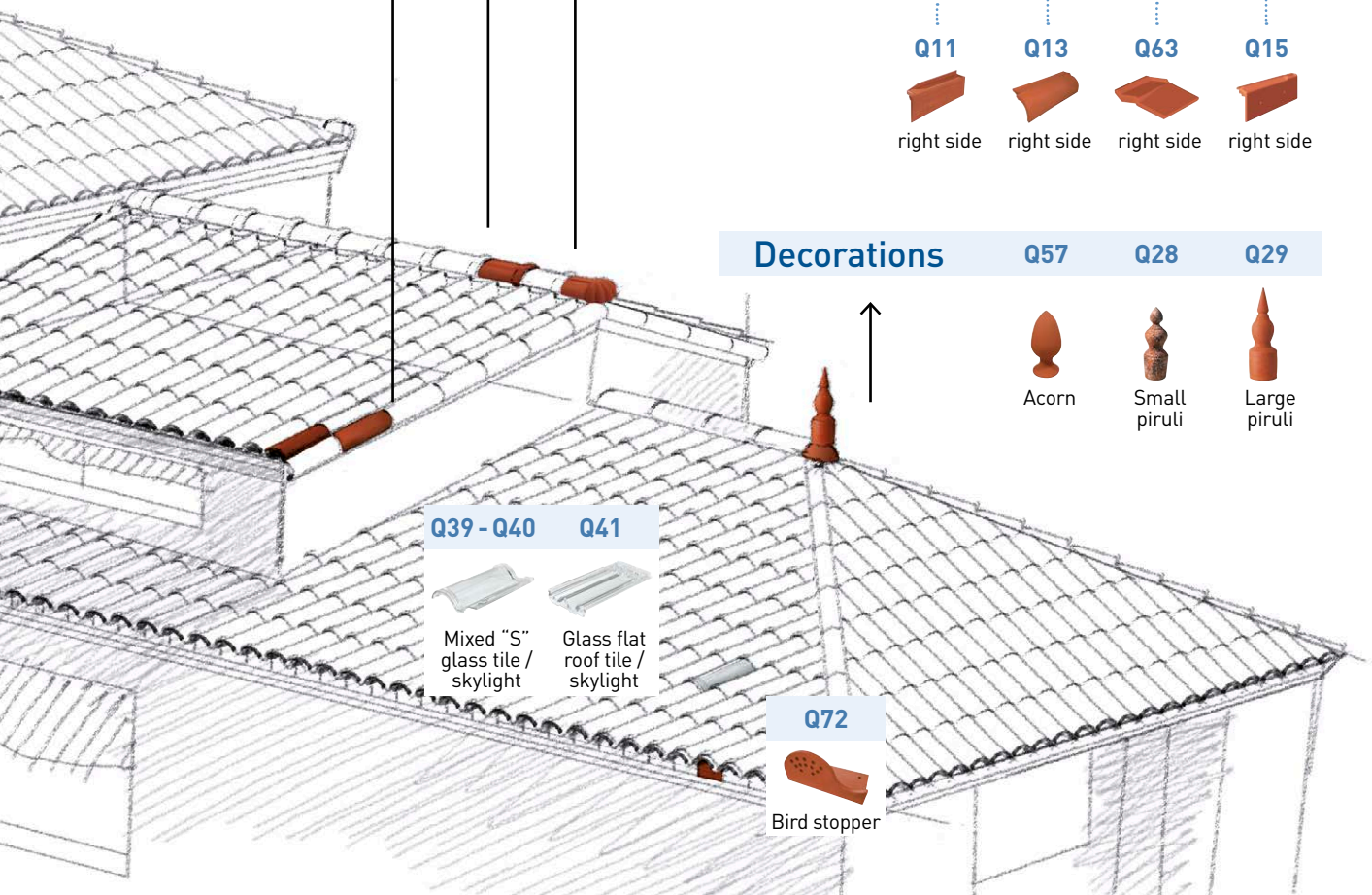

Q39 - Q40 **Q41**

	
Mixed "S" glass tile / skylight	Glass flat roof tile / skylight

Q72

Bird stopper



SELECTION

La Escandella



Single H fire supports that allow the tiles to be fired individually at high temperatures, obtaining perfect definition.

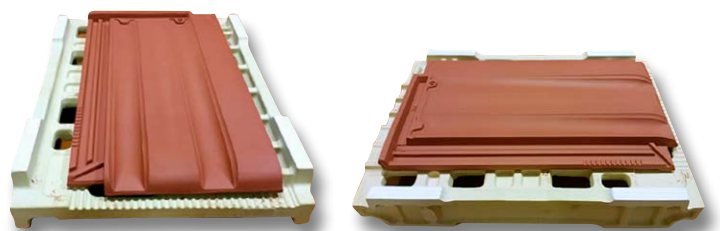

CERAMIC ROOF SOLUTIONS

H-Selection is the result of applying modern manufacturing processes in H-Cassette to a selection of our products, endowing them with numerous functional and aesthetic advantages and benefits.



Excellent flatness

Individual curing of each tile thanks to support in H. Excellent flatness with no contact points.



High definition on each piece

It provides a perfect definition on each piece, made with gypsum moulds, providing a much finer texture.



Low absorption

Higher resistance to ice and mould formation.



Lifetime warranty

Our 100 years of warranty ensure your peace of mind and demonstrate the quality of our manufacturing process.

Innova Roof Tile (TN)

Ample longitudinal overlapping (80mm)

Avoids cutting the tiles, therefore reducing time and installation costs.

Higher resistance

The clay composition together with the perfect pressing allows flexion higher than the required while only weighing 3.5 kg.

Lower absorption (<5%)

High quality clay together with high firing temperature mean higher resistance to ice and mildew.

High definition on each piece

The gypsum moulds provides a perfect finish, obtaining a smoother texture, no contact points nor creases.

Double interlocking

The double interlocking -horizontal and vertical- allows the roof to be more watertight, ensuring its impermeability.

Excellent flatness

H-Cassette manufacturing provides a perfect finish to each product.

Cost reduction

Its large format (11.5units/m²) and strapping every 6 units, as well as its packaging on pallets of 216 and 288 units, reduce installation costs

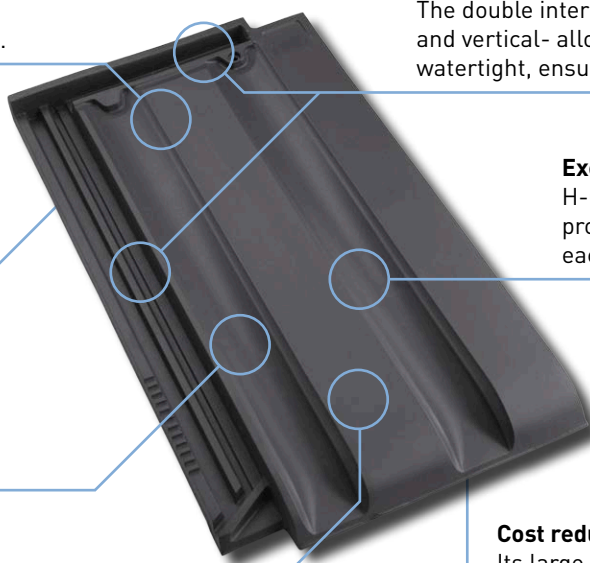

EN 539-2
Test of frost resistance



EN 539-1
Impermeability test



EN 538
Flexural strength test



EN 1024
Geometric characteristics

Dimensions*	a: 465 mm; b: 258 mm; c: 30 mm
Pieces per m ²	11.5
Weight piece	3,500 gr
Longitudinal fit**	396 mm (+5 mm/-75 mm)
Transversal fit**	214 mm (± 1 mm)
Laid method	Straight / Broken bond pattern

	Application Standard	Requirements	INNOVA
Flexural Strength test	EN 538	Resistance > 900N	Above
Impermeability	EN 539-1	Complies with level 1	Above
Frost Resistance	EN 539-2	Complies 150 cycles	Above
Geometric Characteristics	EN 1024	Flatness ≤ 1,5% Straightness ≤ 1,5%	Complies Complies

*The Tile dimensions indicated in this chart, allow a tolerance of approximately 2%.

**Theoretic value: this should be re-calculated on site with the tiles that are to be used.

First course batten should be 20mm (0.78") higher than all succeeding course battens to provide a vertical alignment and to assure a symmetrical installation.

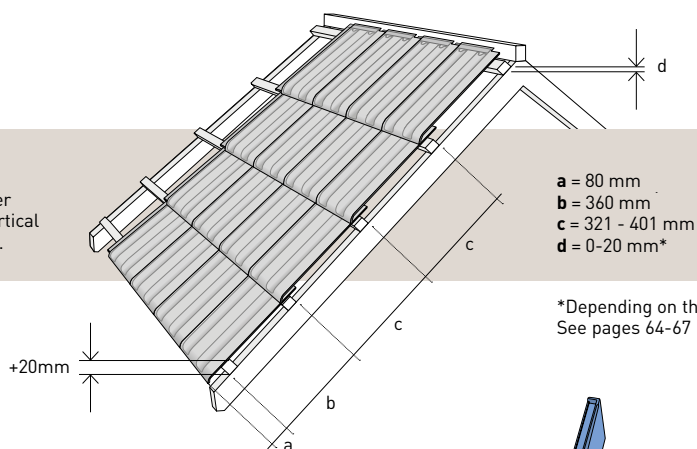

- a = 80 mm
- b = 360 mm
- c = 321 - 401 mm
- d = 0-20 mm*

*Depending on the slope. See pages 64-67 ridge section.

Laid method

Straight bond:

1. The starter course will begin with the **Q116*K** right side course, continuing with the full tiles to complete the eave. The tiles structuring the eave will have to overlap the side course and together one to another. We will finish the eave with the **Q115*K** left side course.
2. The second course will be started again installing the **Q116*K** right side course and doing the same as in step 1.
3. This exposure is continued through each successive course till the ridge.

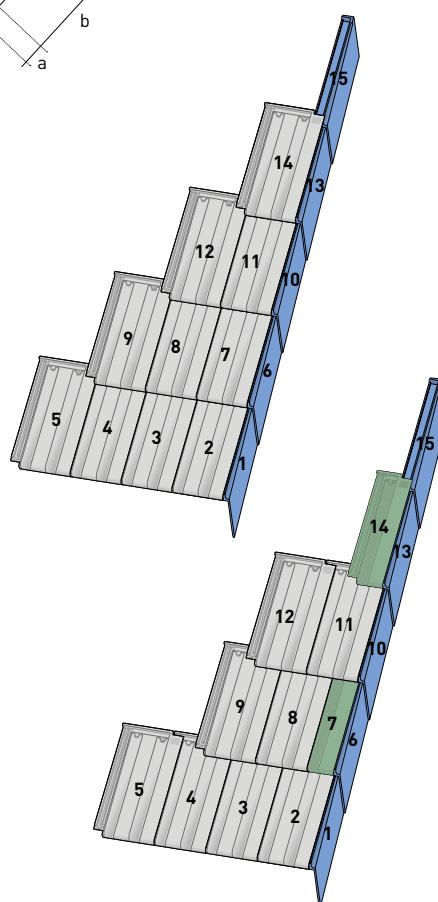

Broken bond:

1. The starter course will begin with the **Q116*K** Right side course, continuing with the full tiles to complete the eave. The tiles structuring the eave will have to overlap the side course and together one to another. We will finish the eave with the **Q115*K** Left side course.
2. The second course will be started again with the **Q116*K** Right side course, continuing with Half tile **Q119*K** and will be laid to provide the proper vertical exposure. This exposure is continued through each successive course.
3. All joints of the second course and succeeding courses should be at the center line of the previous course, alternating half tiles (**Q119*K**) and full tiles at the start and at the end of each course.

NOTE: A control line between 3 and 5 rows of tiles (maximum) is recommended.

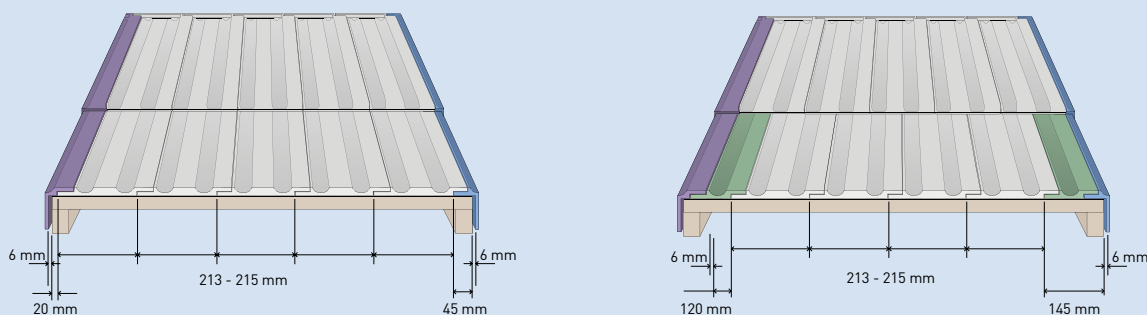

- **Q115*K** Innova/Vienna left side course klinker
- **Q116*K** Innova/Vienna right side course klinker
- **Q119*K** Innova half roof tile klinker

Vienna Roof Tile (TV)

Ample longitudinal overlapping (80mm)
 Avoids cutting the tiles, therefore reducing time and installation costs.

Double interlocking
 The double interlocking -horizontal and vertical- allows the roof to be more watertight, ensuring its impermeability.

Higher resistance
 The clay composition together with the perfect pressing allows exion higher than the required while only weighing 3.45 kg.

Excellent flatness
 H-Cassette manufacturing provides a perfect finish to each product.

Lower absorption (<5%)
 High quality clay together with high ring temperature mean higher resistance to ice and mildew.

High definition on each piece
 The gypsum moulds provides a perfect nish, obtaining a smoother texture, no contact points nor creases.

Cost reduction
 Its large format (11.5units/m²) and strapping every 6 units, as well as its packaging on pallets of 216 and 288 units, reduce installation costs.

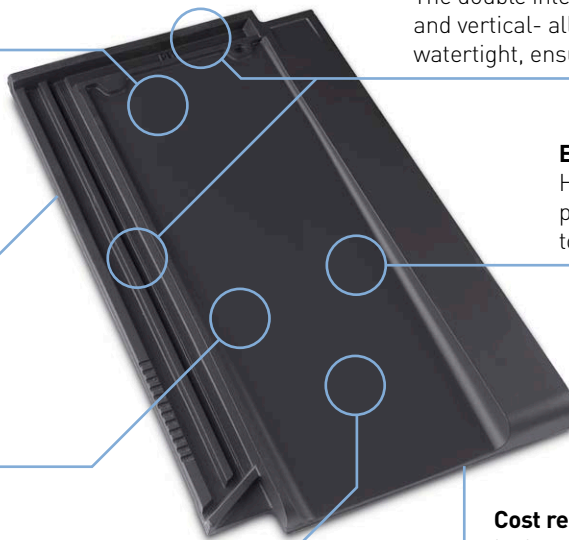

Dimensions*	a: 465 mm; b: 258 mm; c: 30 mm
Pieces per m²	11.5
Weight piece	3,450 gr
Longitudinal fit**	396 mm (+5 mm/-75 mm)
Transversal fit**	214 mm (± 1 mm)
Laid method	Straight bond pattern

	Application Standard	Requirements	VIENNA
Flexural Strength test	EN 538	Resistance > 900N	Above
Impermeability	EN 539-1	Complies with level 1	Above
Frost Resistance	EN 539-2	Complies 150 cycles	Above
Geometric Characteristics	EN 1024	Flatness ≤ 1,5% Straightness ≤ 1,5%	Complies Complies

*The Tile dimensions indicated in this chart, allow a tolerance of approximately 2%.
 **Theoretic value: this should be re-calculated on site with the tiles that are to be used.

Laid method

Laying the roof

1. The starter course will begin with the Q116*K right side course, continuing with the full tiles to complete the eave. The tiles structuring the eave will have to overlap the side course and together one to another. We will finish the eave with the Q115*K left side course.

2. The second course will be started again installing the Q116*K right side course and doing the same as in step 1.

3. This exposure is continued through each successive course till the ridge.

NOTE: A control line between 3 and 5 rows of tiles (maximum) is recommended.

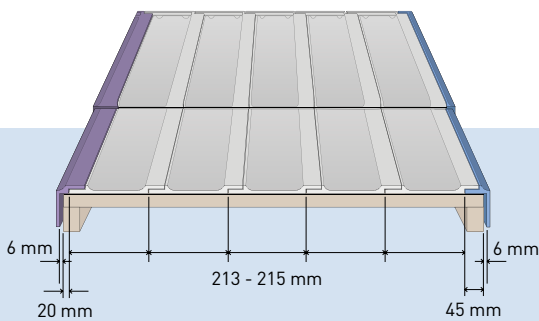
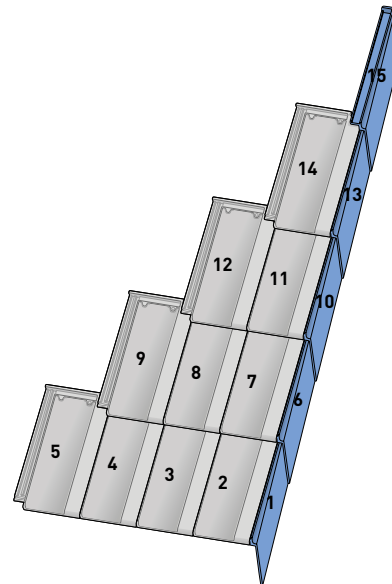

First course batten should be 20mm (0.78") higher than all succeeding course battens to provide a vertical alignment and to assure a symmetrical installation.

- Q115*K Innova/Vienna left side course klinker
- Q116*K Innova/Vienna right side course klinker

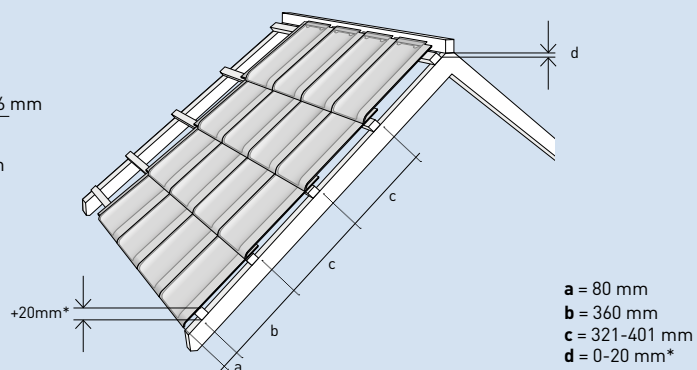

*Depending on the slope. See pages 64-67 ridge section.

Planum Roof Tile (TI)

Higher resistance

The clay composition together with the perfect pressing allows for a strength higher than the required while only weighing 3.5 kg.

High definition on each piece

Los moldes de yeso proporcionan un acabado perfecto. The gypsum moulds provide a perfect finish, obtaining a smoother texture, no contact points nor creases.

Lower absorption (<5%)

High quality clay together with high firing temperature mean higher resistance to ice and mildew.

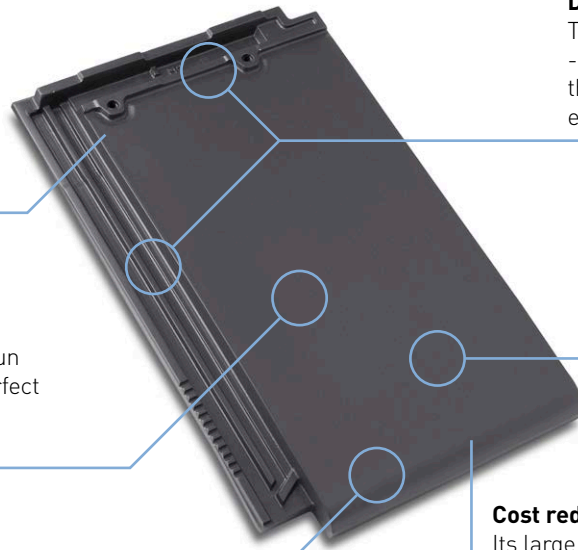

Double interlocking

The double interlocking -horizontal and vertical- allows the roof to be more watertight, ensuring its impermeability.

Excellent flatness

H-Cassette manufacturing provides a perfect finish to each product.

Cost reduction

Its large format (11 units/m²) and strapping every 5 units, as well as its packaging on pallets of 240 and 320 units, reduce installation costs.



Test of frost resistance



Impermeability test



Flexural strength test



Geometric characteristics

Dimensions*	a: 444 mm; b: 280 mm; c: 32 mm
Pieces per m ²	11
Weight piece	3,500 gr
Longitudinal fit**	370 mm (± 6 mm)
Transversal fit**	237 mm (+2 mm/-1 mm)
Laid method	Cross bond pattern

	Application Standard	Requirements	PLANUM
Flexural Strength test	EN 538	Resistance > 900N	Above
Impermeability	EN 539-1	Complies with level 1	Above
Frost Resistance	EN 539-2	Complies 150 cycles	Above
Geometric Characteristics	EN 1024	Flatness ≤ 1,5% Straightness ≤ 1,5%	Complies Complies

*The Tile dimensions indicated in this chart, allow a tolerance of approximately 2%.

**Theoretic value: this should be re-calculated on site with the tiles that are to be used.

Laid method

Laying the roof

Planum roof tile can be laid on a continuous frame, which has to be completely flat in order to ensure the right laying of tiles and their fixing components (to avoid water-leaking); or on a discontinuous frame or battens, which will be fixed by building a batten counter batten deck or by fixing them directly to the frame.

The laying of Planum roof tile is carried out by broken bond (also referred as cross bond) as follows:

A. The starter course will begin with the Planum right side course (Rake trim - **Q88*K**) (A1) from the eave to the ridge (A1-A5...).

B. The starter course will begin with a full tile (B1). The tiles structuring the eave will have to overlap the side course and fit together one to another.

C. The second course will be started with half tile -**Q85*K**- (C1) and will be laid to provide the proper vertical exposure. This exposure is continued through each successive course. All joints of the second course and succeeding courses should be at the center line of the previous course, alternating half tiles **Q85*K** (C1) and full tile at the start and at the end of each course.

NOTE: A control line between 3 and 5 rows of tiles (maximum) is recommended.

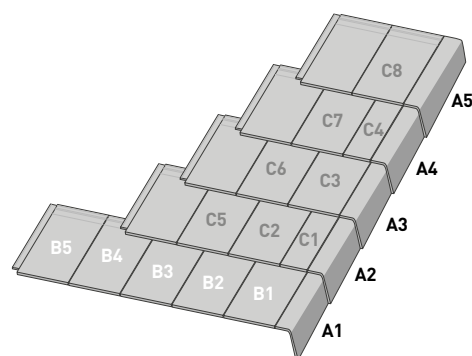

- Planum roof tile
- **Q85*K** Planum Half roof tile
- **Q88*K** Planum right side course / rake
- **Q89*K** Planum left side course / rake

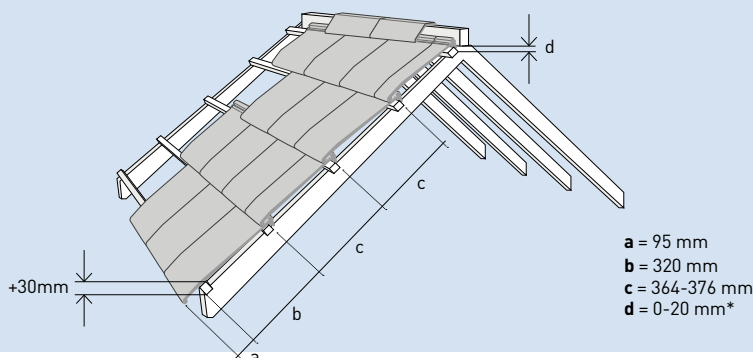
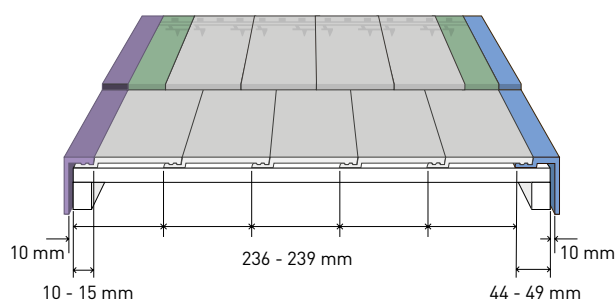

*First course batten should be 30 mm (1.18") higher than all succeeding course battens to provide a vertical alignment and to assure a symmetrical installation

- a = 95 mm
- b = 320 mm
- c = 364-376 mm
- d = 0-20 mm*

*Depending on the slope. See pages 64-67 ridge section.

Visum3 Roof Tile (TW)

3 in 1 tile

Visum3 is a patented interlocking tile with an innovative triple cambered design that gives the appearance of three plain tiles.

Wide range of colors

Its triple exclusive decoration system offers a broader range in tones and hues, so no two tiles are alike.

Lower absorption (<5%)

High quality clay together with high firing temperature mean higher resistance to ice and mildew.

Double interlocking

The double interlocking -horizontal and vertical- allows the roof to be more watertight, ensuring its impermeability.



Cost reduction

Its large format (11.5 units/m²) and strapping every 6 units, as well as its packaging on pallets of 216 and 288 units, reduce installation costs.

Excellent flatness

H-Cassette manufacturing provides a perfect finish to each product.

Higher resistance

The clay composition together with the perfect pressing allows exion higher than the required while only weighing 3.5 kg.



EN 539-2
Test of frost resistance



EN 539-1
Impermeability test



EN 538
Flexural strength test



EN 1024
Geometric characteristics

Dimensions*	a: 471 mm; b: 280 mm; c: 35 mm
Pieces per m ²	11.5
Weight piece	3,500 gr
Longitudinal fit**	187 mm (+4 mm/-10 mm)
Transversal fit**	435 mm (± 1 mm)
Laid method	Cross bond pattern

	Application Standard	Requirements	VISUM3
Flexural Strength test	EN 538	Resistance > 1200N	Above
Impermeability	EN 539-1	Complies with level 1	Above
Frost Resistance	EN 539-2	Complies 150 cycles	Above
Geometric Characteristics	EN 1024	Flatness ≤ 1,5% Straightness ≤ 1,5%	Complies Complies

*The Tile dimensions indicated in this chart, allow a tolerance of approximately 2%.

**Theoretic value: this should be re-calculated on site with the tiles that are to be used.

Laid method

Laying the roof

Visum3 roof tile is laid on a discontinuous frame or battens, which will be fixed by building a batten counter batten deck or by fixing them directly to the frame.

The laying of Visum3 roof tile is carried out by broken bond (also referred as cross bond) as follows:

A. The Starter course will begin with a Visum3 Right side course klinker (**Q99*K**). Then continue with full tiles Visum3 all the course.

B. The second course will start again with the **Q99*K** followed by Visum3 Right Half roof tile (**Q100*K**), creating a cross bond visual effect, with full tiles all the course and ending on the left side with the Visum3 Left Half roof tile (**Q102*K**) and its Left side course (**Q101*K**).

C. The process should be repeated alternating steps A and B until reaching the ridge.

NOTE: A control line between 3 and 5 rows of tiles (maximum) is recommended.

D. At top course, beneath ridge line, the excess of **Q99*K** right side course must be cut, as shown below.

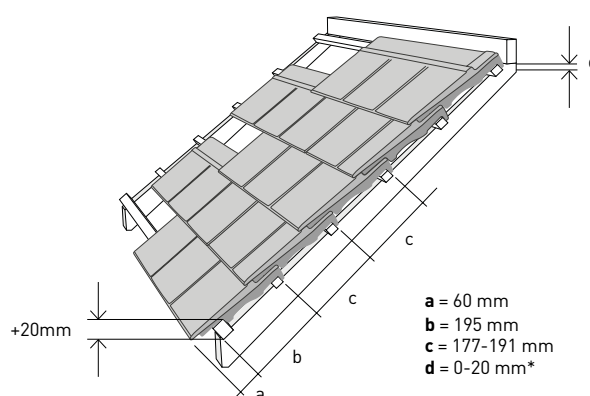
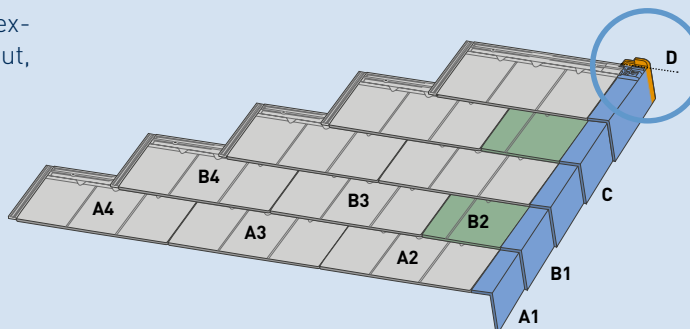

First course batten should be 20 mm (3/4") higher than all succeeding course battens to provide a vertical alignment and to assure a symmetrical installation

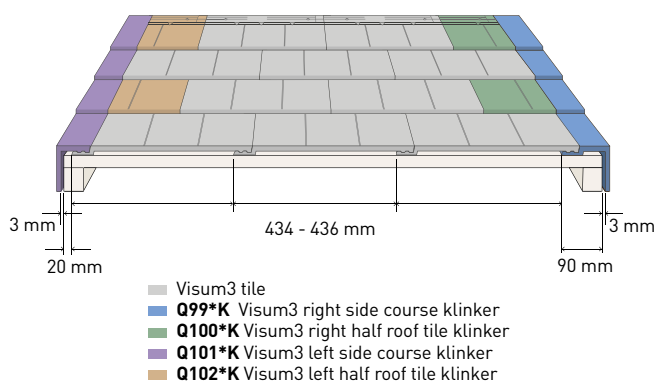

*Depending on the slope. See pages 65-67 ridge section.

TN / TV / TI / TW Accessories

The Accessories, made of the same material as the tiles, are to deal with special cases or discontinuous points of the roof.

These parts are essential for finishing particular spots where standard tiles do not join perfectly, making sure the roof is waterproof, uniform and aesthetically pleasing.

Below is a general scheme of a roof, showing various of these particular points and the special parts used to deal with them.

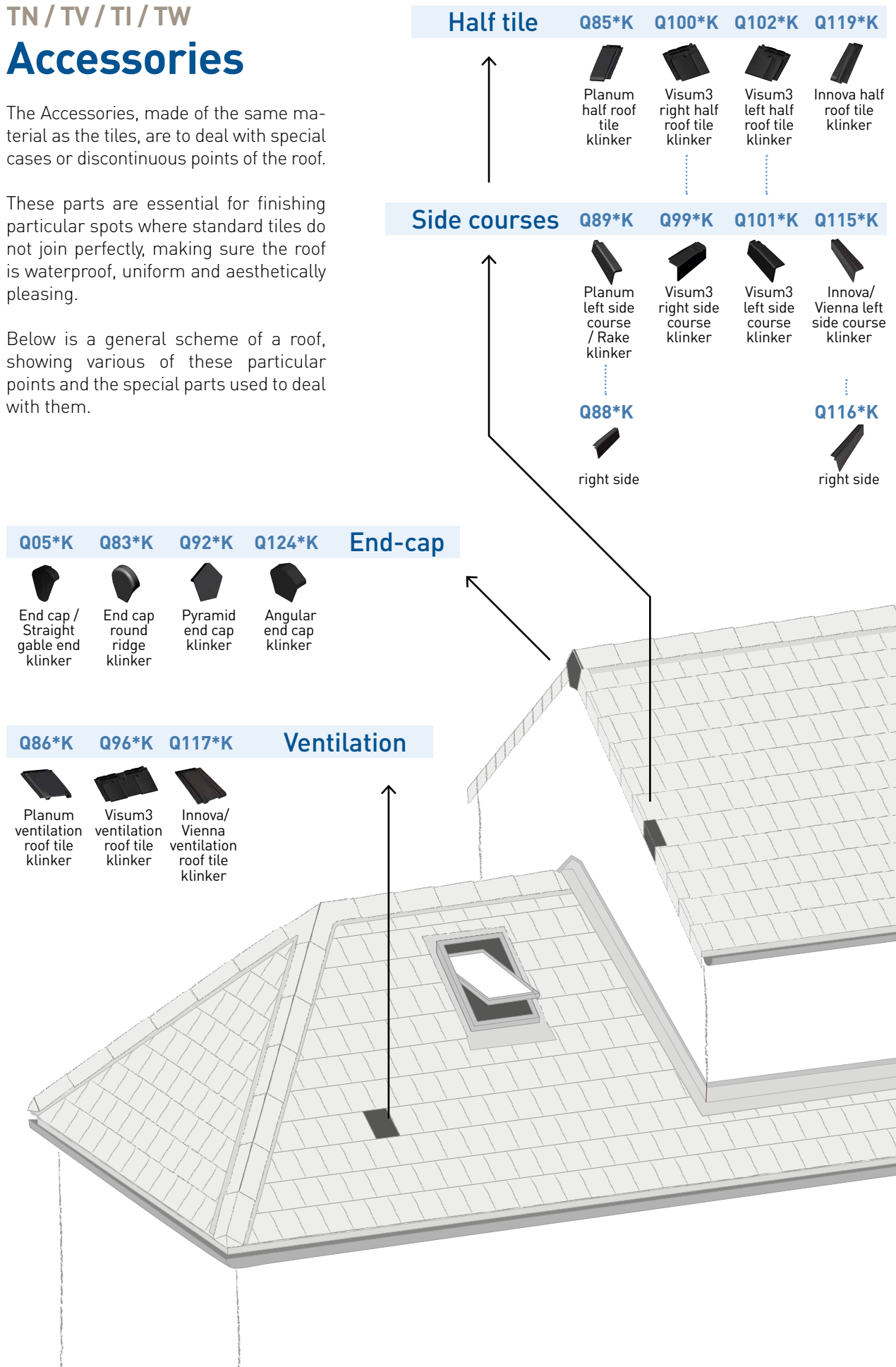

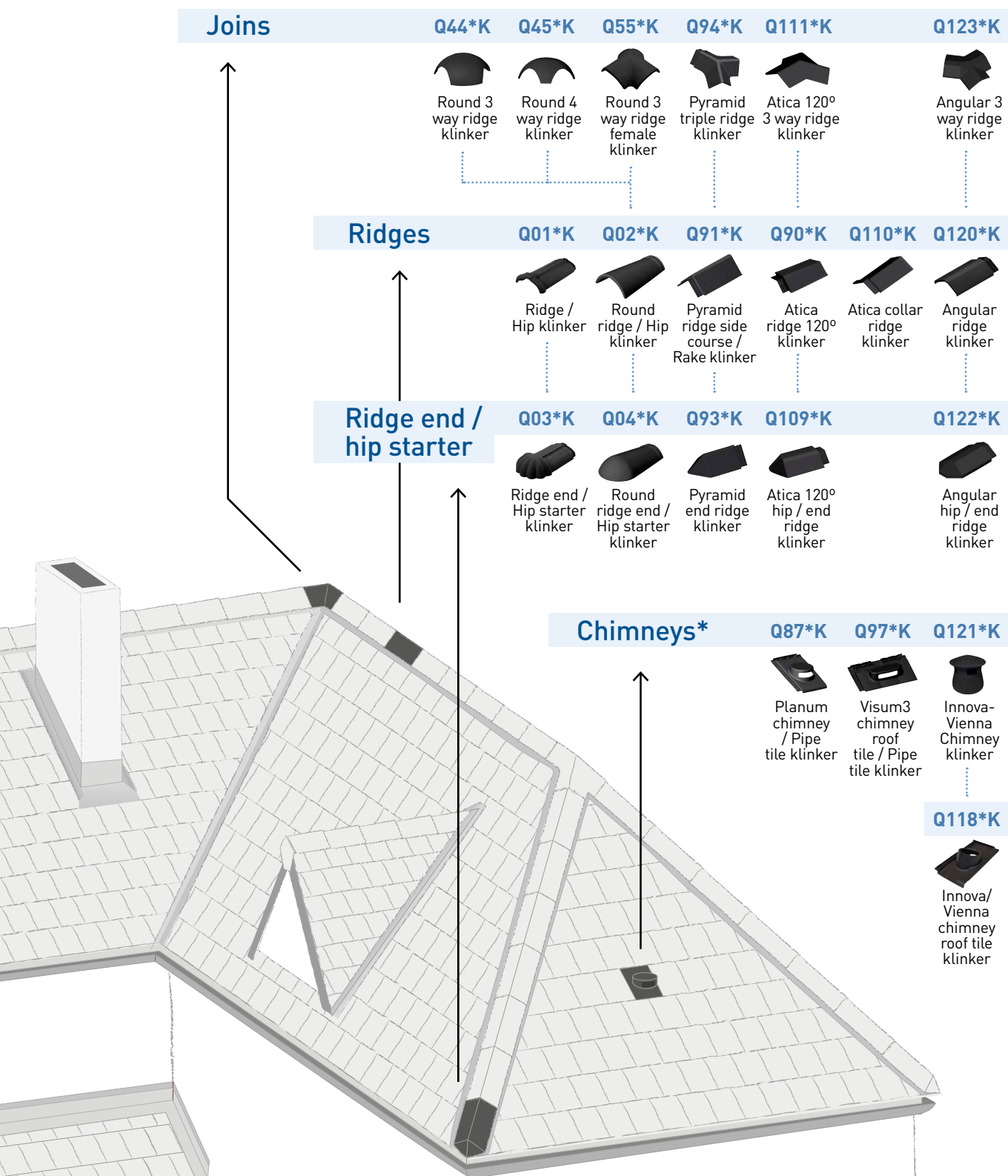

* For chimney supports to be most effective, parts must be as close as possible to the ridge line.

Installation details

Side courses

As well as being attractive, side courses act as gutters. For this, an overhang of a few centimetres over the gable should be allowed for.

The fixings used will be polyurethane mastics or fillers as glue; or metal nails or self-drilling screws with flexible washers. Whenever the tile is perforated in order to nail it, the hole must be sealed.

MIXED "S" ROOF TILE

TG-TP | Right-angle side course with half tile

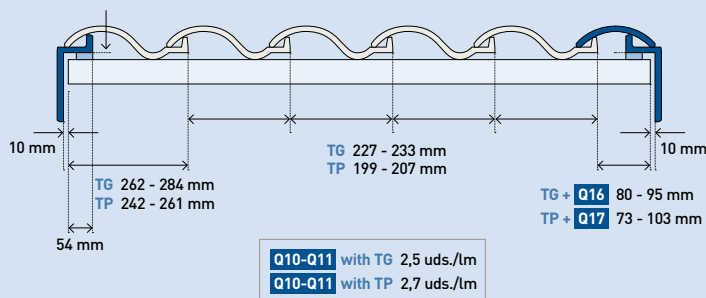

Raise the rake by +20mm on the first batten or, if the installation allows it, nail the rake to the side to prevent it from falling.
 For Small Mixed tiles, do not use a stud or shim.

TG-TP | Straight side course with double tile

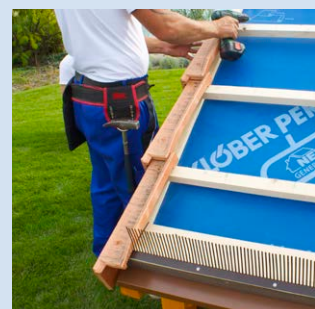
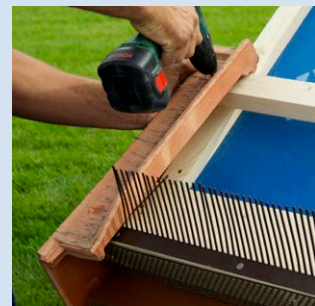
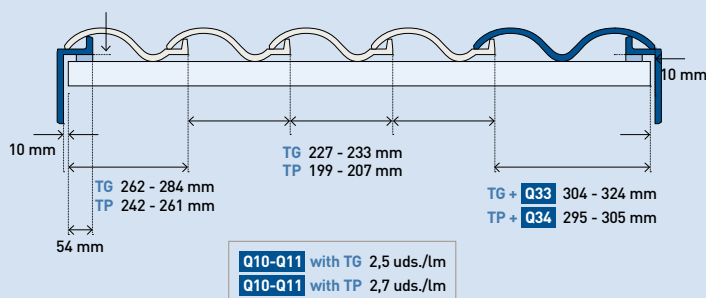

MIXED "S" ROOF TILE

TG-TP | Round side course **Q12 Q13** with Half tile **Q16 Q17**

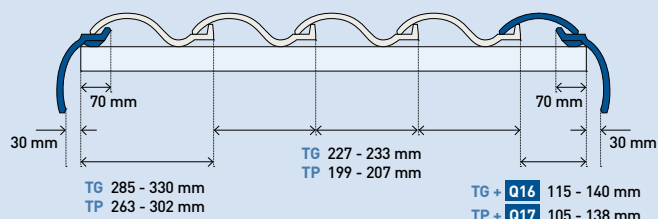

TG-TP | Round side course **Q12 Q13** with Double tile **Q33 Q34**

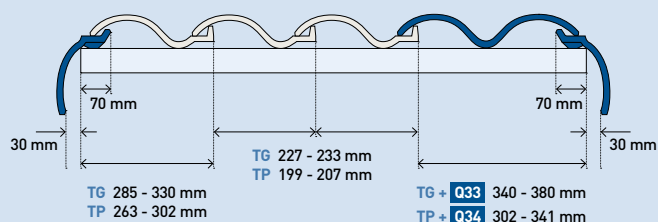

TG-TP | Bardelis side course **Q62 Q63** with Half tile **Q16 Q17**

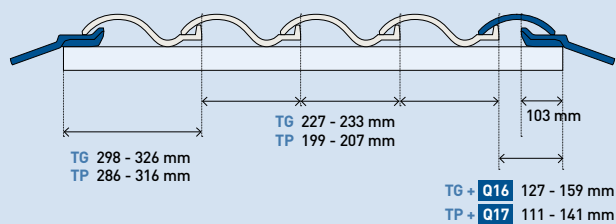

TG-TP | Bardelis side course **Q62 Q63** with Double tile **Q33 Q34**

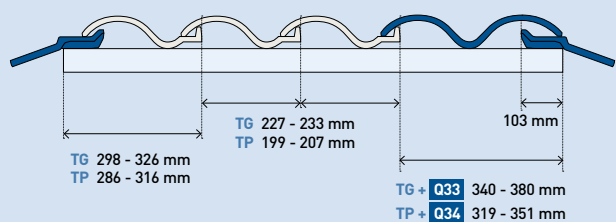

FLAT ROOF TILE

TL | Straight side course Q14 Q15

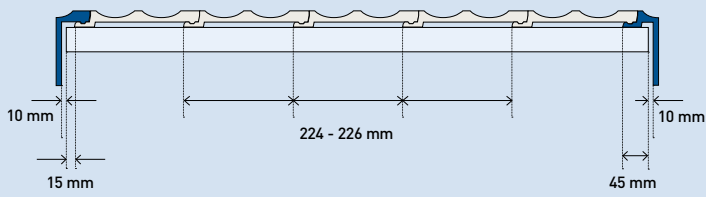

TL | Straight side course with half tile Q14 Q15 Q18

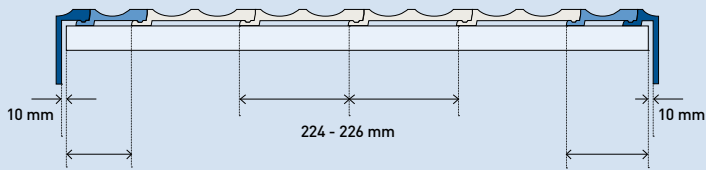

PLANUM ROOF TILE

TI | Straight side course Q88 Q89

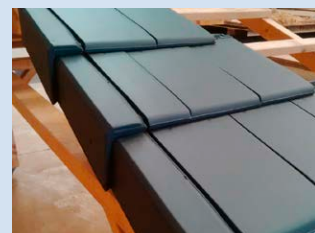
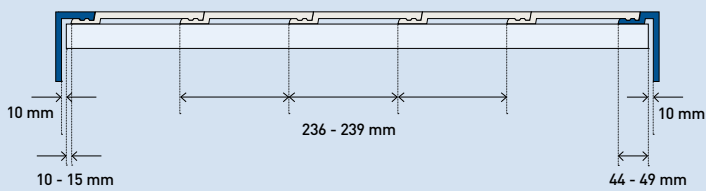

TI | Straight side course with half tile Q88 Q89 Q85

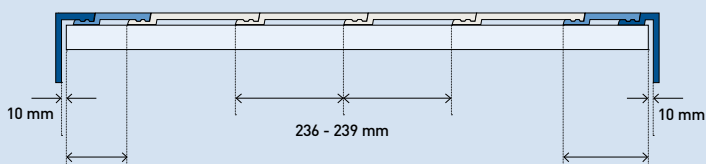

INNOVA ROOF TILE*

TN | Straight side course Q115 Q116

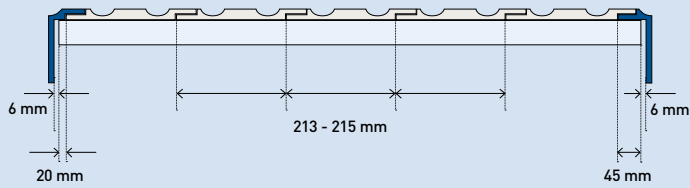

TN | Straight side course with half tile Q115 Q116 Q119

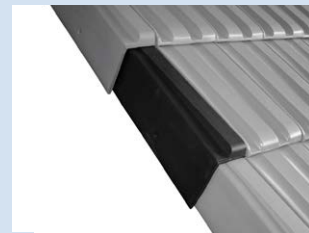
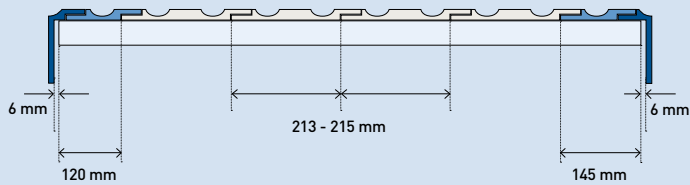

VIENNA ROOF TILE*

TV | Straight side course Q115 Q116

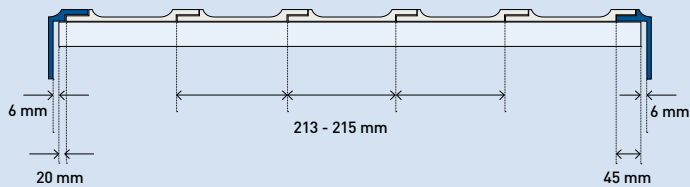

***Note:** Start laying the roof from the right with the right side-course and complete the full row of tiles, then continue with the rest. Unlike other tile types, you do not lay all side course tiles first, followed by the rest of the tiles.

Ridge

Ridge tiles must be fitted so as to ensure they are watertight against rain and provide protection from the dominant winds.

For a gabled roof, both fields must be built up to the ridge, to create a horizontal line.

All the tiles of the upper final horizontal row must be fixed, either on the battens or directly onto the field, using the smallest possible amount of waterproof mortar.

Once the top layer of tiles has been laid, a wedge (Q08) is placed in the curve of each of the tiles of the last horizontal row (fig.1), or the tiles are filled with an under ridge tile (Q70 and Q35).

If the ridge goes over battens, ventilating ridge band will be used for the ridge and the hips (CAM01) to ensure proper roof ventilation, laying it on the centre of the uppermost batten and nailing or stapling the roll to it. Once it is fastened to the batten, the flexible part of the roll is spread onto the roof, the protective tape is removed from the adhesive strip, and it is stuck down on the roof.

Then the ridge tiles are laid, ensuring a minimum overlap of 5cm, lying so they face away from the dominant winds, which brings rain in. These tiles will be fastened along the whole length of the ridge.

Where the ridge meets the gable, this is dealt with using a special part, the end-cap, which is fastened using nails or screws.



The ventilating ridge band (CAM01) is installed first on the ridge and stuck onto the upper part of the tiles and the wedges so that it is properly watertight.

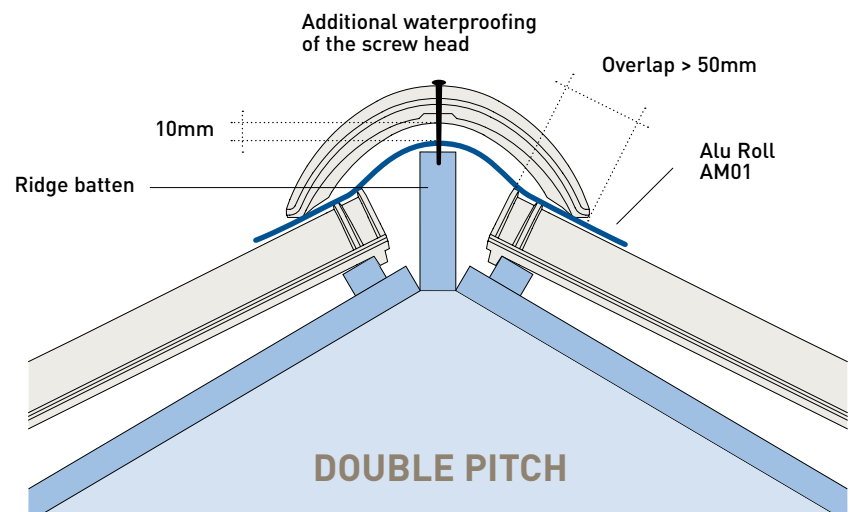



Ridge tiles must be laid facing away from the dominant winds

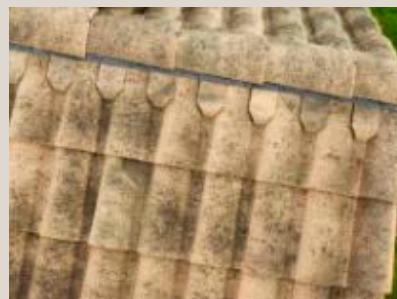
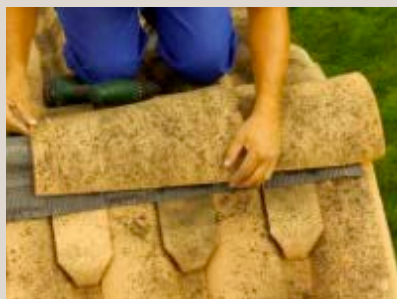

The ridge tiles must be fastened to the roof using a ridge hook (CAM07-CAM27), laying tiles sequentially, each tile on top of the previously placed one. For dry laying, both the Standard Ridge tile (Q01) and the Round Ridge tile (Q02) will need to be laid over ridge roll.

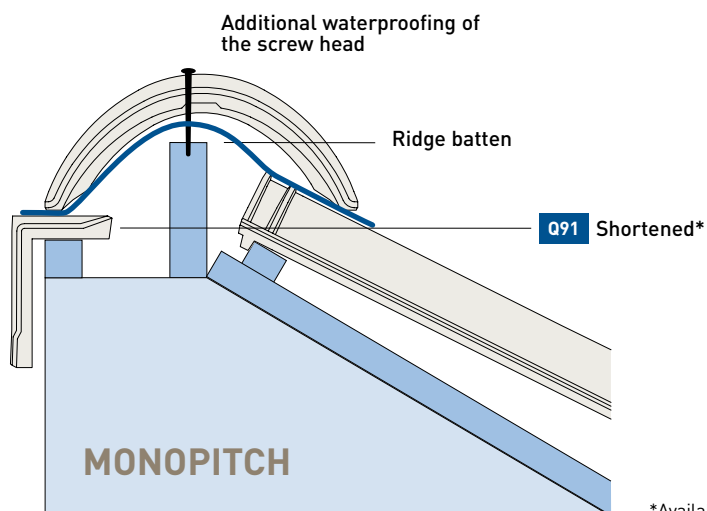

*Available upon request

Q01 Ridge installation

TG-TP / TL / TI / TN / TV

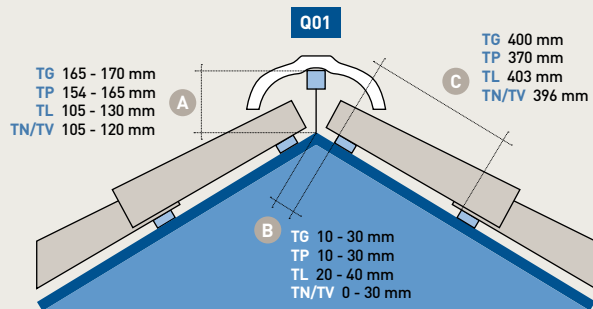

Note: Depending on the slope of the roof, the height at which the ridge will be laid must be taken into account to ensure an overlap greater than 50mm.



Q01 Ridge installation with Mixed tile TG-TP

TG

Slope	A	B	C	Overlapping
30% / 17°	165	30	400	70
36% / 20°	165	30	400	70
49% / 26°	170	10	400	60

TP

Slope	A	B	C	Overlapping
30% / 17°	160	30	370	80
36% / 20°	165	30	370	65
49% / 26°	154	10	370	80

TL

Slope	A	B	C	Overlapping
30% / 17°	130	40	403	80
49% / 26°	125	40	403	60
87% / 41°	105	20	403	65

TN / TV

Slope	A	B	C	Overlapping
30% / 17°	120	30	396	80
49% / 26°	115	20	396	70
87% / 41°	105	0	396	<50

Q02 Ridge installation

TG-TP / TI / TW / TN / TV

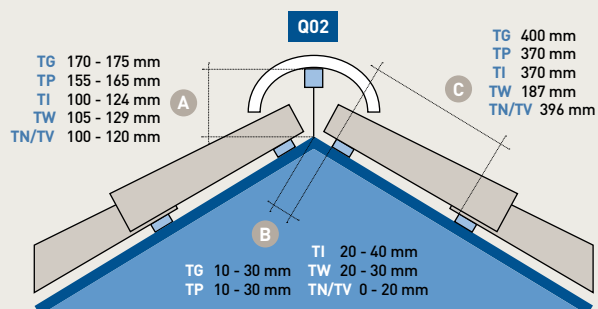

Q02 Ridge installation with Mixed tile (TG-TP)



Q02 Ridge installation with Planum Tile (TI)



TG

Slope	A	B	C	Overlapping
30% / 17°	175	30	400	60-90
36% / 20°	175	30	400	60-90
49% / 26°	170	10	400	60-90

Note: The two overlap lengths obtained refer to the widest and narrowest part of the ridge, in relation to the tile below.

TP

Slope	A	B	C	Overlapping
30% / 17°	160	30	370	70
36% / 20°	165	30	370	65
49% / 26°	155	10	370	65

TI

Slope	A	B	C	Overlapping
49% / 26°	124	40	370	60-80
87% / 41°	100	20	370	60-80

TW

Slope	A	B	C	Overlapping
49% / 26°	129	30	187	77-95
87% / 41°	105	20	187	65-85

TN / TV

Slope	A	B	C	Overlapping
49% / 26°	120	20	396	70-90
87% / 41°	100	0	396	60-80

Q90 - Q110 Ridge installation

TI / TW / TN / TV

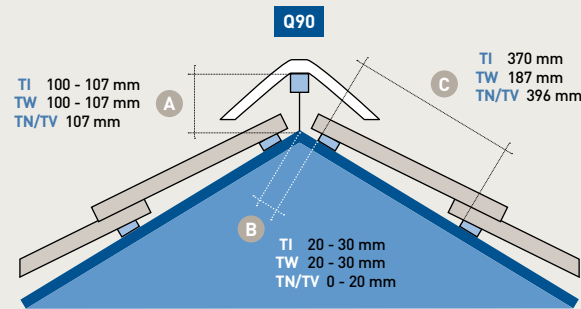

TW

Slope	A	B	C	Overlapping
49% / 26°	100	30	187	95
87% / 41°	107	20	187	80

TI

Slope	A	B	C	Overlapping
49% / 26°	100	30	370	95
87% / 41°	107	20	370	80

TN / TV

Slope	A	B	C	Overlapping
49% / 26°	107	20	396	85-90
87% / 41°	107	0	396	80-90



Q90 Ridge installation with Planum Tile (TI)

Q91 Ridge installation

TI / TW

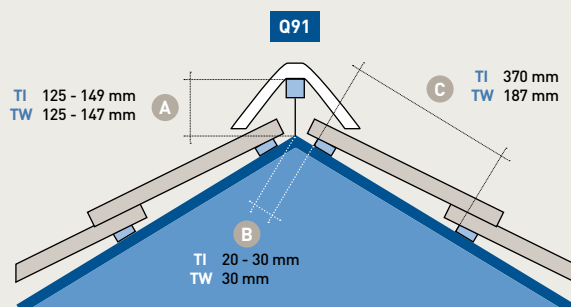

TI

Slope	A	B	C	Overlapping
49% / 26°	149	30	370	110
87% / 41°	125	20	370	100

TW

Slope	A	B	C	Overlapping
49% / 26°	147	30	187	110
87% / 41°	125	30	187	90



Q91 Ridge installation with Planum Tile (TI)

Q120 Ridge installation

TI / TW / TN / TV

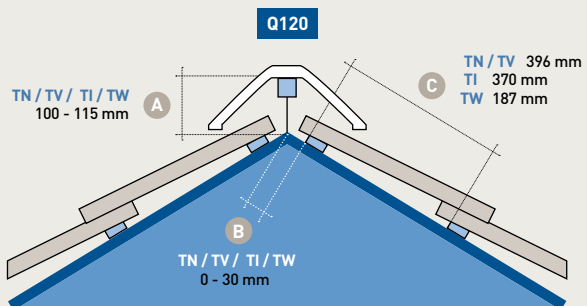

TI

Slope	A	B	C	Overlapping
49% / 26°	115	20-30	370	80-90
87% / 41°	100	0	370	80



Q120 Ridge installation with Planum Tile (TI)

TW

Slope	A	B	C	Overlapping
49% / 26°	115	20-30	187	80-90
87% / 41°	100	0	187	80

TN / TV

Slope	A	B	C	Overlapping
49% / 26°	115	20-30	396	80-90
87% / 41°	100	0	396	80

Ridge installation with Under Ridge (TG)

To finish off the field where it meets the ridge, we recommend using the Under Ridge tile (Q70) or the Double Under Ridge tile (Q71) (fig.1). This ensures better ventilation and faster construction.

If, at the end of the ridge line, a full tile will not fit, to avoid cutting tiles a short tile can be used on the last horizontal course, the 2/3 Mixed Under Ridge (Q35) closing this row on the right side-course with a 2/3 Double Under Ridge tile (Q37) (fig.2).

- Mixed roof tile
- Q71 (TG) Large double under ridge tile
- Q33 (TG) Double large Mixed roof tile
- Q35 (TG) 2/3 Large under ridge tile
- Q37 (TG) Double large under ridge tile

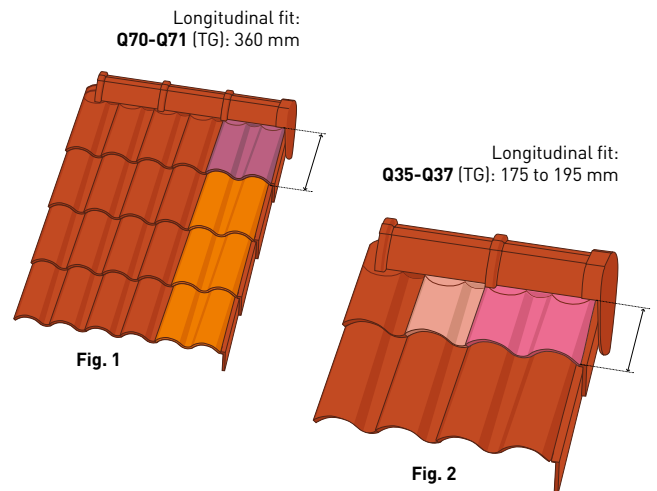

Q01 Ridge installation with Under Ridge tile (Q70-Q71)

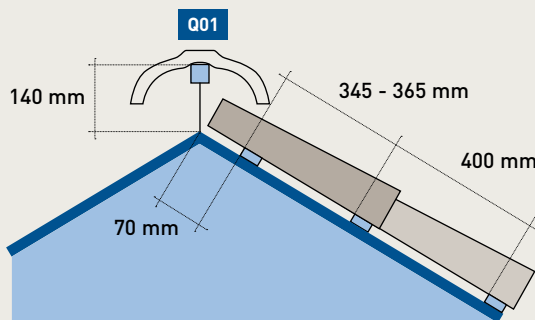

Q01 ridge installation with 2/3 Under Ridge tile (Q35-Q37 and Q36-Q38)

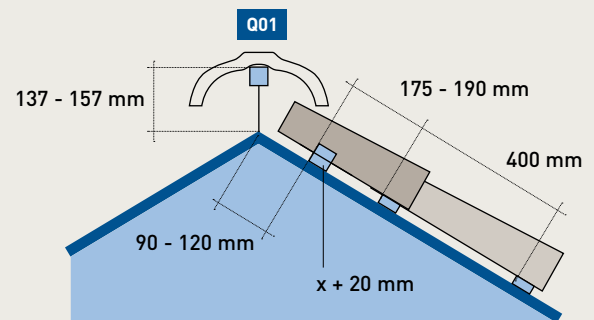

- > Minimum overlap is always 50mm.
- > The values given are those for Ridge tile Q01. They must be recalculated if using the Circular Ridge tile, Q02.
- > The measurements given are based on a slope at 30%.



After installing the Under Ridge tile Q70 on the last course of the field, the ridge band (CAM01) is laid on the ridge batten, adhering perfectly to the upper face of the tiles and preventing water from entering.

Then the Ridge tile (Q01 or Q02) is laid, which can be capped on the side courses by the Ridge End-cap (Q05 or Q83).

Ridge tiles are fixed to the roof using a Ridge Hook (CAM07-CAM27). The head of the hook must be sealed to prevent the passage of water.

Laying the 2/3 Mixed tile (Q56) (TG)

When the calculation for the number of tiles needed for the roof identifies the need to cover a length shorter than half a full tile, a 2/3 Mixed Tile (Q56) can be used, avoiding the need to cut full tiles.

This part can carry out two functions:
 - Under Ridge tile
 - Eaves for a concealed gutter or eave

Laying the 2/3 Large Mixed tile (Q56) (TG)

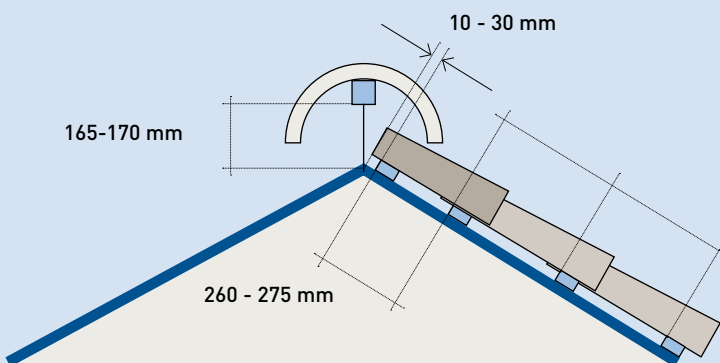

The right side course can be finished in two different ways::

- 1. Using half tiles:** These must be cut to fit the part. The cut must be made such that the 2/3 interlock with the half tile is not inhibited.
- 2. Using double tiles:** The roof cover can be finished with double tiles, using the half tile on the last course, with the side course as shown in item 1.

Eave

The first tile of the field (eave tile), and all course end-tiles, must overhang the edge by at least 5cm and, where necessary, can be supported at the front to keep the same pitch as the rest of the rows on the field.

Installation of an eave with gutter / drain

TG-TP / TL / TI / TW / TN / TV

Rain water will be evacuated without backing up or wetting elements underlying the roof. In many cases a gutter will be installed for this.

If the eaves are to have a gutter, before fitting the eave tiles, the gutter support braces must be fixed to the field. The gutter in its turn must be installed on a slope greater than 1%, oriented towards the downspout. The tiles will overhang along the full line of the eaves, ensuring that they channel water into the gutters.

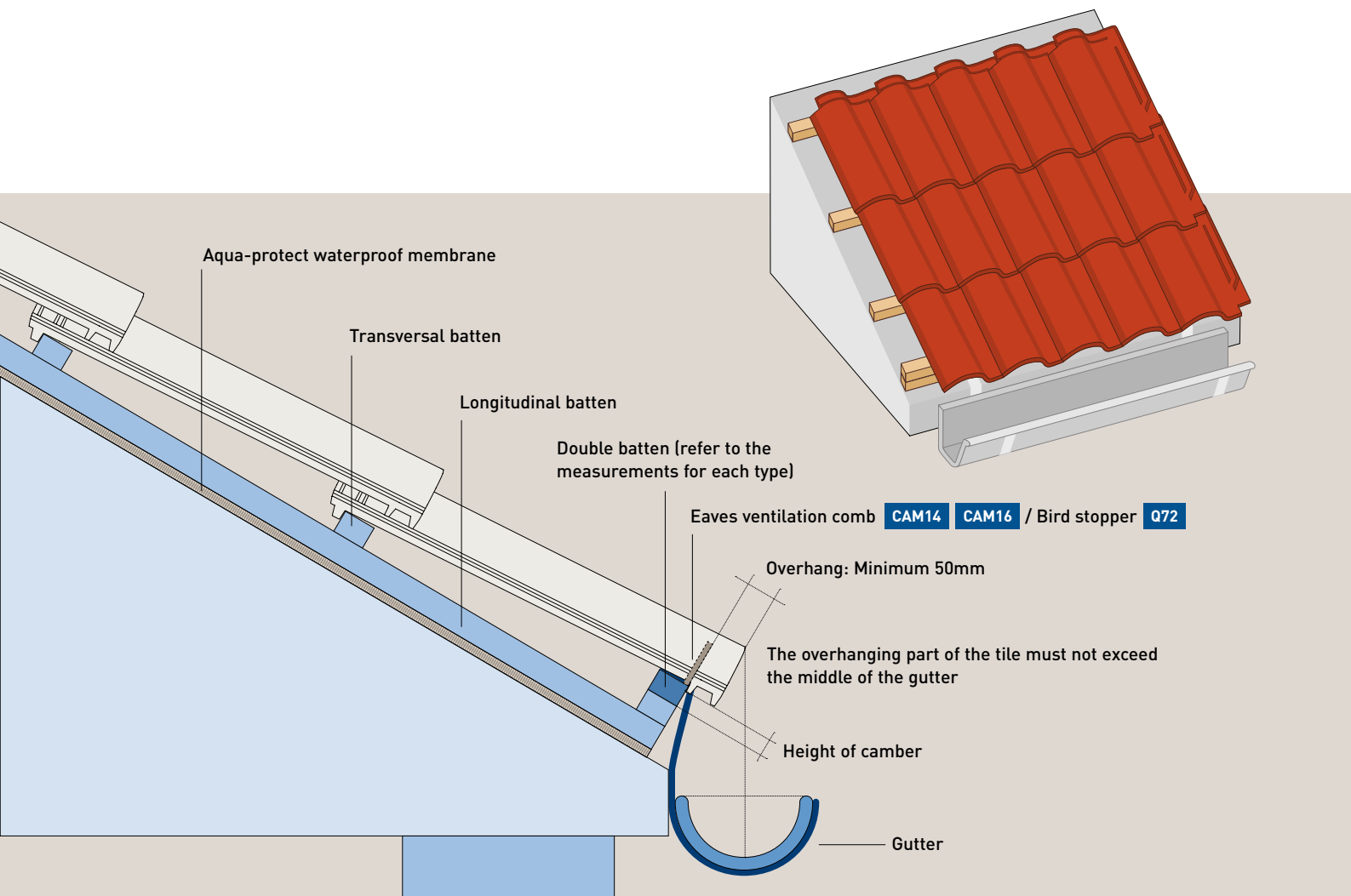

Installation of an eave drip-edge

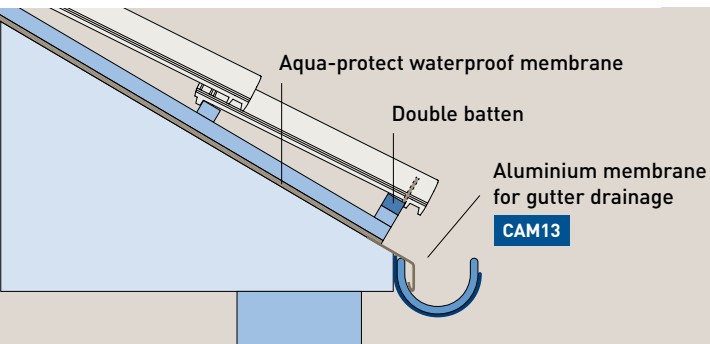

The membrane must cover the whole roof area in order to evacuate any water that runs over it or snow that penetrates.

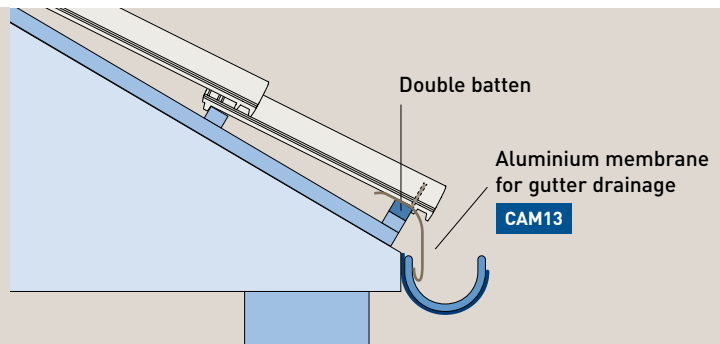

Installation when tiles do not overlap the gutter enough.



Installation of eave with pan and cover TG-TP

Our installation process is as follows:

1. We trace a line perpendicular to the maximum slope line, which will be the reference point for laying the eave covers and eave pans parallel to it.
2. The eave line must be raised by 3cm with respect to the roof plane.
3. We begin by laying the eave covers from the left, spacing them at 2.5 to 3.5cm, depending whether they are Small or Large Mixed Tiles.

4. We then lay the eave pans on the eave covers.

5. Then we start hooking the Mixed Tiles onto the eave piece hooks, so that the caps of the Mixed Tiles discharge onto the eave pans.

The rest of the field is laid like any other Mixed Tile roof. The effect produced is that of a Mediterranean style roof.

Eave Pan - Channel with a different slope TG

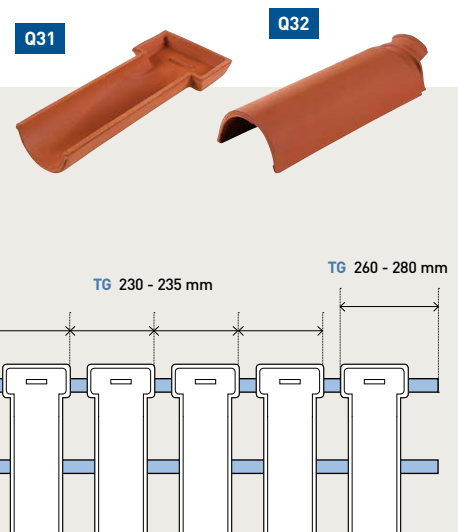
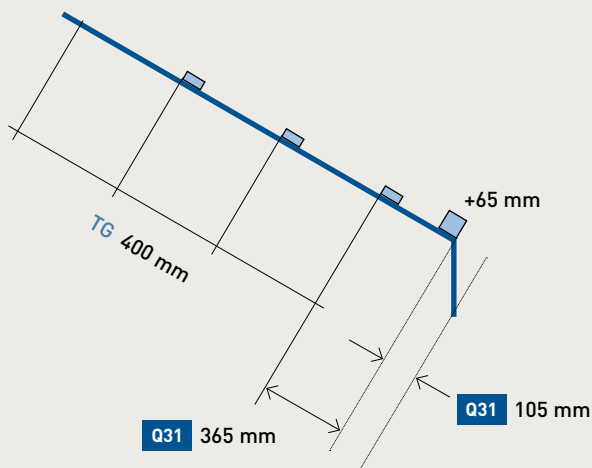

Note: The slope shown is 30%. For any other slope, the measurements must be recalculated.



With this type of eaves, the slope is very important. The tile is more or less exposed depending on the slope.

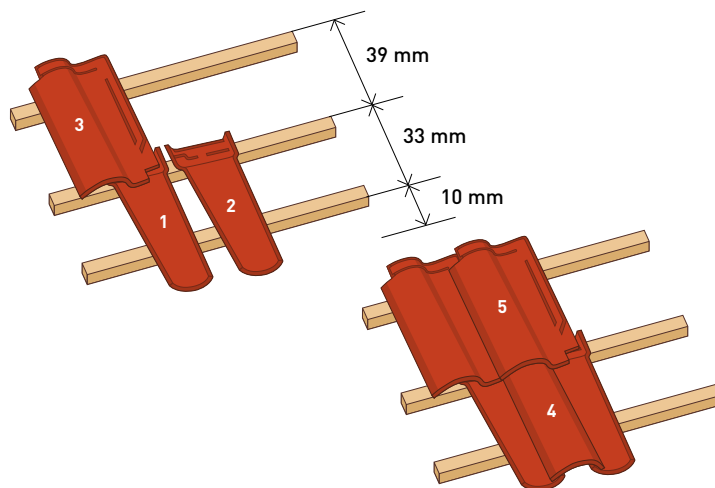
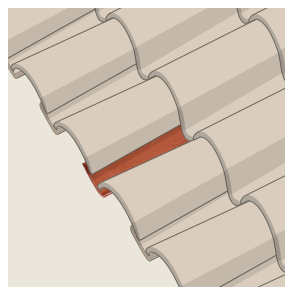
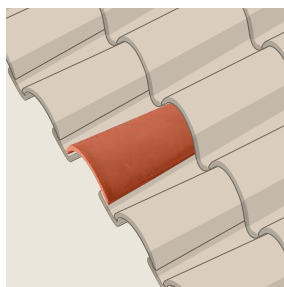

Q81

Q80



Eave Pan - Channel with same slope TG

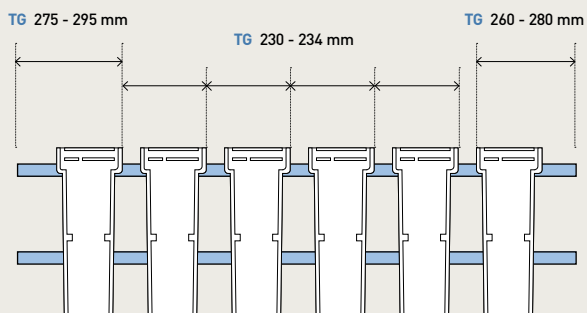

Note: The methods discussed are valid for both half tiles and double tiles.

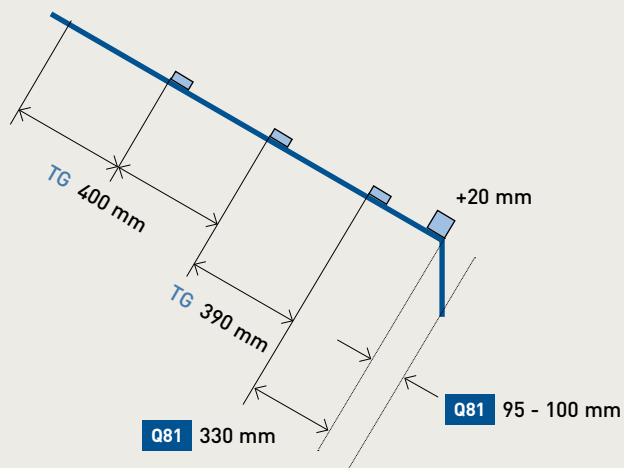

When using Eave Pans - Channel with same slope (Q80-Q81), there is no need to install a double batten to raise them.

Installation of an eave with concealed gutter / flashing

TG-TP / TL / TI / TW / TN / TV

This is when the gutter is placed between two horizontal courses of tiles, near the eaves, and it is recommended when the field is longer than 12m.

The eave line will be finished in the same way as an eave without gutter, although to avoid water penetrating around the gutter tile, it must be protected by a waterproof membrane, which overlaps the tiles and gutter (CAM13 Aluminium membrane for gutter drainage).

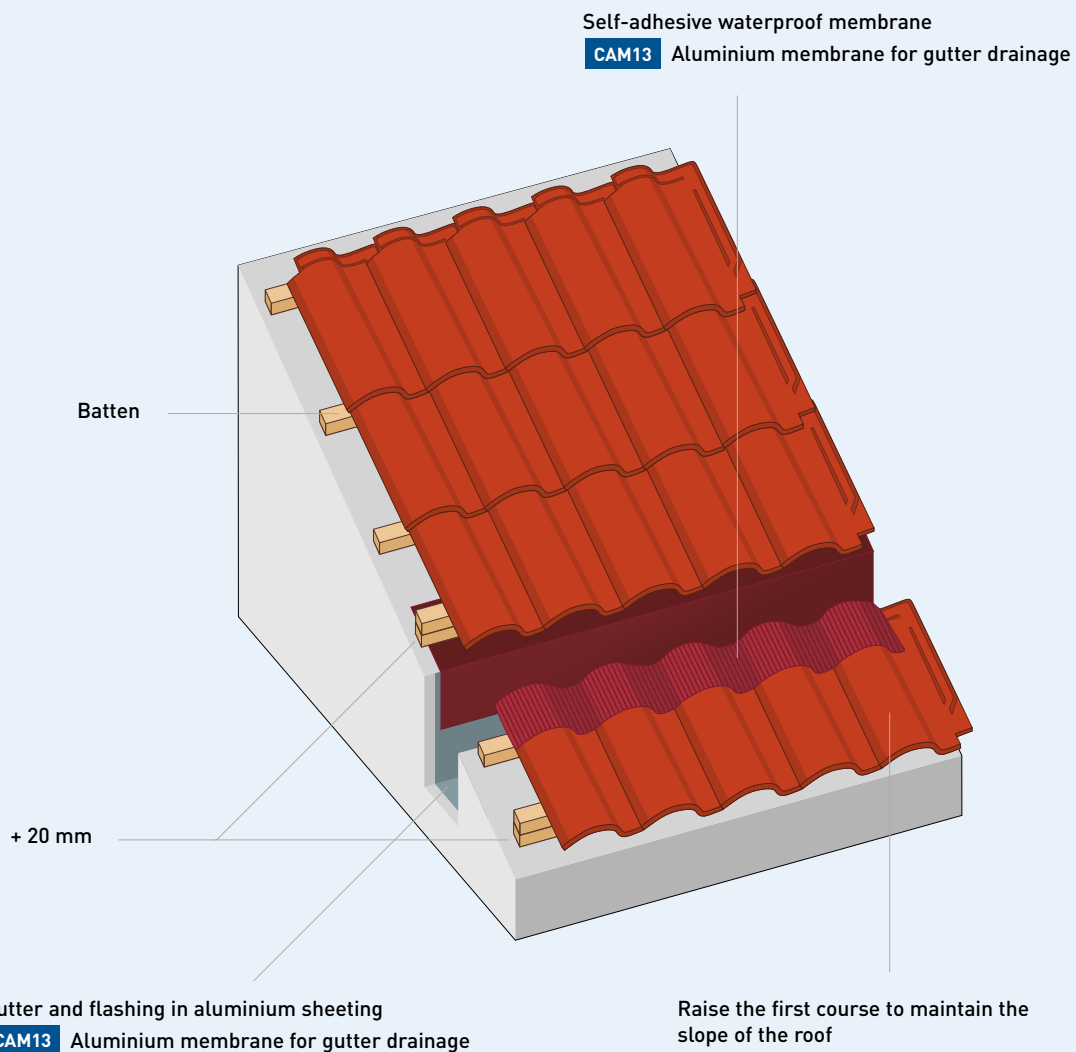

Eave accessories installation

Laying eave accessories, such as Comb or Bird-stopper, is done before laying the first course of tiles. The eaves line must never be filled with cement or similar, but must be left clear to facilitate air flow and must be protected against birds, insects and rodents or the like. For this, the Eave Comb or Bird-stopper is used.

Bird stopper: TG Q72

Ceramic eave closure. Prevents entry of birds and small rodents, maintains good roof ventilation. It fits in aesthetically with the roof, making its colours and materials more consistent.

When installing a bird-stopper, the first batten is laid at the same height as for the rest of the roof, and a second batten is added to support the bird-stopper.

When installing a bird-stopper, transversal play in the Mixed tile is limited by interlocking with the bird-stopper.



Eaves ventilation comb TG-TP-TL-TI-TN-TV CAM14 CAM16

PVC comb for eave closure. Prevents entry of birds and small rodents, maintains good roof ventilation.

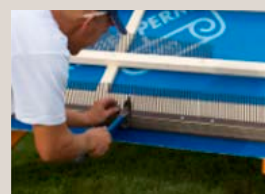
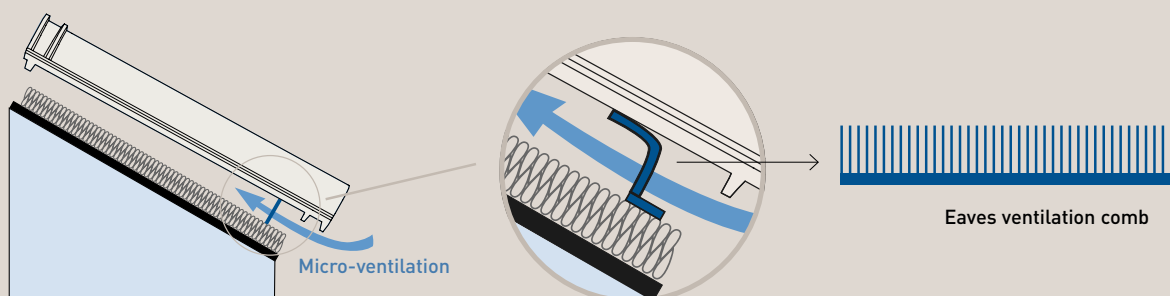

Hip

To lay a hip, it is imperative that ridge tiles be used, proceeding as for the laying of the ridge.

The tiles arriving from each field must be cut parallel to the line of the hip.

The membrane or ridge band (CAM01) must be fixed to the ridge batten with screws. The screw head must be sealed to prevent the passage of water.

Laying should start at the intersection of the hip with the eaves, proceeding from bottom to top. The ridge tiles/caps must overlap the cut tiles by at least 5cm on each side.

Where the eaves meet the hip, we recommend using an End Ridge tile for a perfect finish, aesthetical and functional.

Do not pack or fill in the ridge or hip void, as this would completely block ventilation and would cause cracking, chipping and even peeling in areas subject to frost.

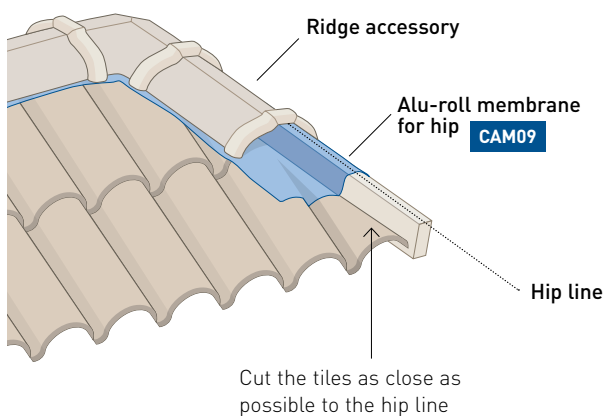

Hip parts depending on the type

TG-TP-TL
Q01 Q02

TN-TV-TI-TW
Q02 Q90 Q110 Q120



To install the hip, first the full tiles are laid on the left-hand battens, and the cut-line marked up. Then the tiles are cut. The same process is then followed on the right-hand side of the hip.

We place the hip ridge hooks and then lay the wooden slat, on top of which we lay ridge band to cover the upper part.

We dry-lay the last hip tile, and will later finish off with hip clips.

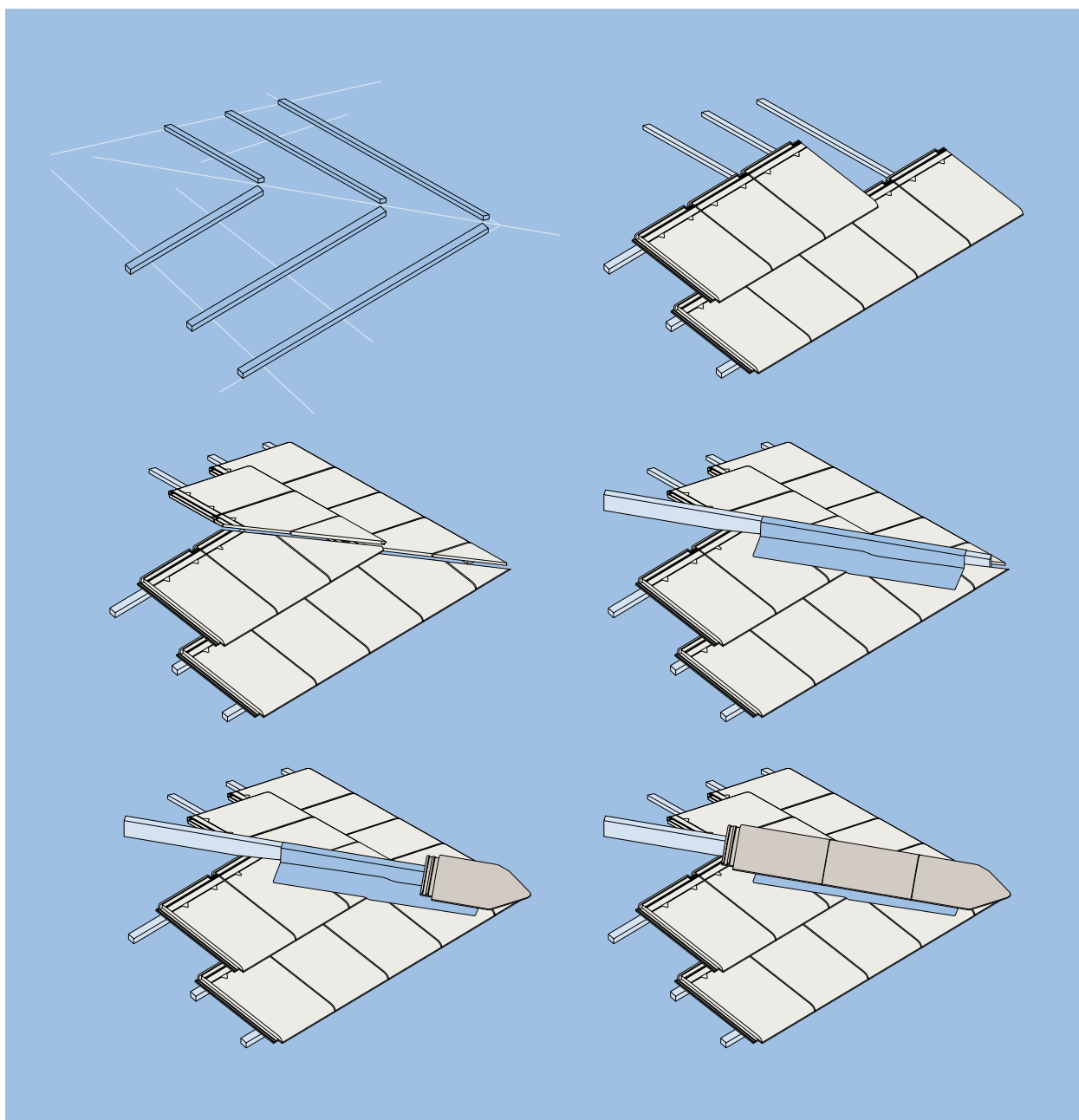

Valley TG-TP / TL / TI / TW / TN / TV

The eave line is the area of the roof that receives the most water, so it is a critical point of watertightness. Once the battens have been laid parallel to the line of the valley on both fields, laying begins from bottom to top, laying an impermeable barrier along it (ridge band for valleys).

The fastening of this material must be flexible: glue, mastic or similar.

Where it meets the ridge line, the ridge band must overlap and protect the intersection with the ridge. Where it meets the eaves, the valley must overhang the fascia boards or gutter by the same amount as the eaves (50mm or greater).

Once the area has been made watertight, the tiles are laid on a line parallel to the valley, and must overhang the valley by at least 10cm. The gap between the tiles on the two fields must be at least 15cm. The tiles must be fixed on both sides of the valley.

A poorly installed valley can lead to cracking, chipping and subsequently to peeling in areas subject to frost.

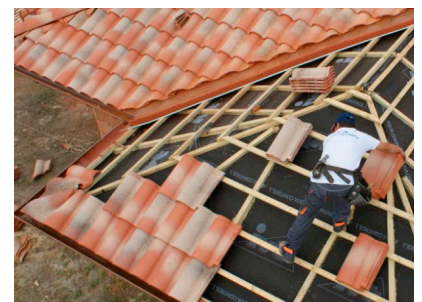
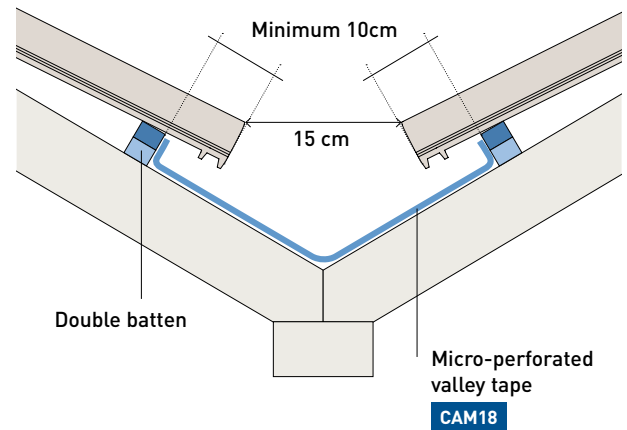

Vertical walls

TG-TP / TL / TI / TW / TN / TV

The following types of intersections are found:

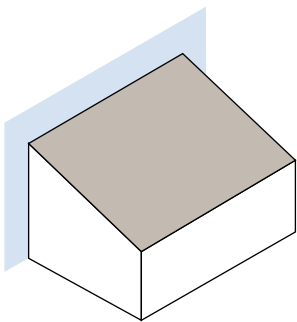

Horizontal upper joint

The tiles are laid in horizontal courses following the references from the master lines and when reaching the upper section, if possible using full tiles, or 2/3 Mixed Tiles (Q56), which are laid head-on against the vertical wall. All the tiles of the last horizontal covering course are fixed to the batten.

Either a waterproof membrane is laid over the last row of tiles, with a minimum overlap of 10cm; or metal flashing that adapts to the shape of the tiles and is fixed to the vertical wall to a height of 25cm.

The membrane or flashing joined to the vertical wall is finished with a metal contour, sealed or let into a channel made for this purpose, in which case it will be set in M-15 mortar.

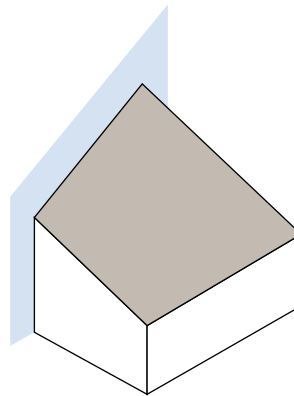

Raked upper joint

This is handled like the previous type, but taking into account that the tiles laid head-on against the vertical wall must be cut parallel to it.

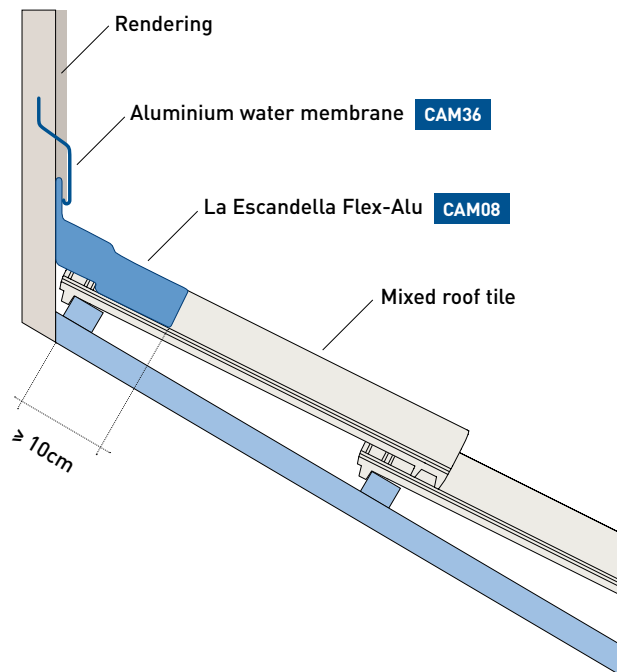

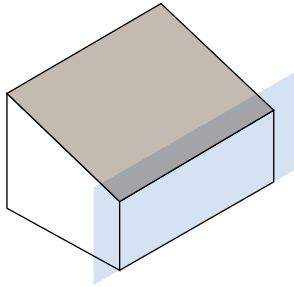

Horizontal lower joint

Since the field channels water onto this joint, it must be collected in a gutter. The solution is similar to that used for hidden guttering.

The guttering is placed in the intended space, taking into account that the material used must be impermeable, and if it is metal it must be correctly protected against corrosion.

The dimensions of the guttering shall meet the UNEEN 612 norms and will be of a size that will facilitate its cleaning. The guttering shall have a minimum slope of 1% to facilitate water evacuation.

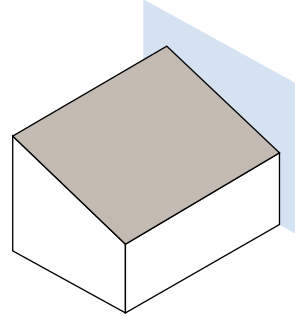

Lateral joint parallel with the maximum slope line

There are two options for this situation:

1. Raked upper joint:

This is handled like the raked upper joint, but taking into account that the tiles laid head-on against the vertical wall must be cut parallel to it.

2. Lateral joint parallel with the maximum slope line:

There are two options for this situation:

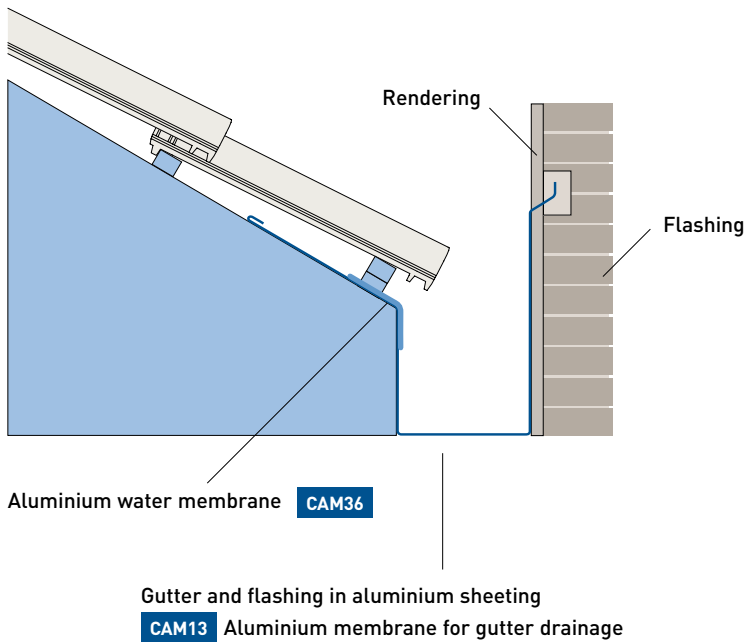

SOLUTION 1:

- Lay the tiles on the field in vertical lines following the line markers from the master lines and, when reaching the lateral join, if possible using full tiles or Half tiles (Q16) or Double tiles (Q56), which are laid head-on against the vertical wall. All the tiles of the first row parallel to the join will be fixed.
- Either a waterproof membrane is laid over the last row of tiles, with a minimum overlap of 10cm; or metal flashing that adapts to the shape of the tiles and is fixed to the vertical wall to a height of 25cm.
- The membrane or flashing joined to the vertical wall is finished with a metal contour, sealed or let into a channel made for this purpose, in which case it will be set in M-15 mortar.

SOLUTION 2:

- This consists of laying a gutter parallel to the maximum slope line, between the tiles and the wall. This is only valid when the water is channelled directly to the eaves or to the component that collects the water from the field (gutter, valley etc.) This join is handled as follows:
- A metal gutter is laid along the join, which overlaps the field by 20cm and will have a vertical rise against the wall of 20cm.
 - A channel is made in the vertical wall, at a height of at least 25cm above the intersection. Metal flashing laid in the channel is set in M-15 mortar and forms a seam with the gutter.
 - The gutter will have a flange on one side for the seam with the metal flashing and to avoid overflow.
 - Tiles are then laid on the field in vertical lines following the marker references by the master lines, remaining at a distance of 15cm from the lateral join and overlapping the gutter by 5cm. All the tiles of the first row will be fixed parallel to the join.

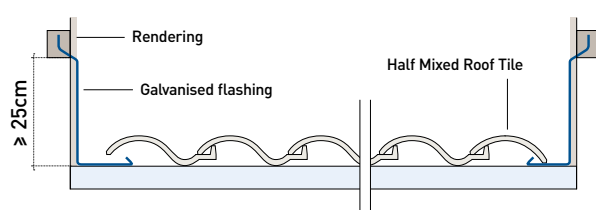
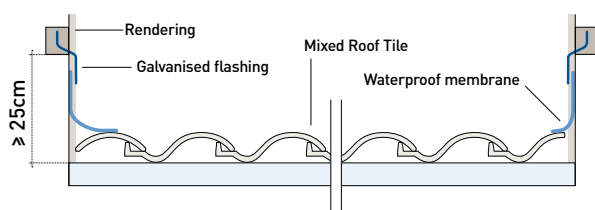

Change of slope

TG-TP / TL / TI / TW / TN / TV

To make a join between two verticals with different gradients, a flexible waterproofing membrane connection system (Flex-Alu) will be used under the tiles on the upper slope, overlapping those of the lower slope, to avoid possible water infiltration.

The following types of intersection are found:

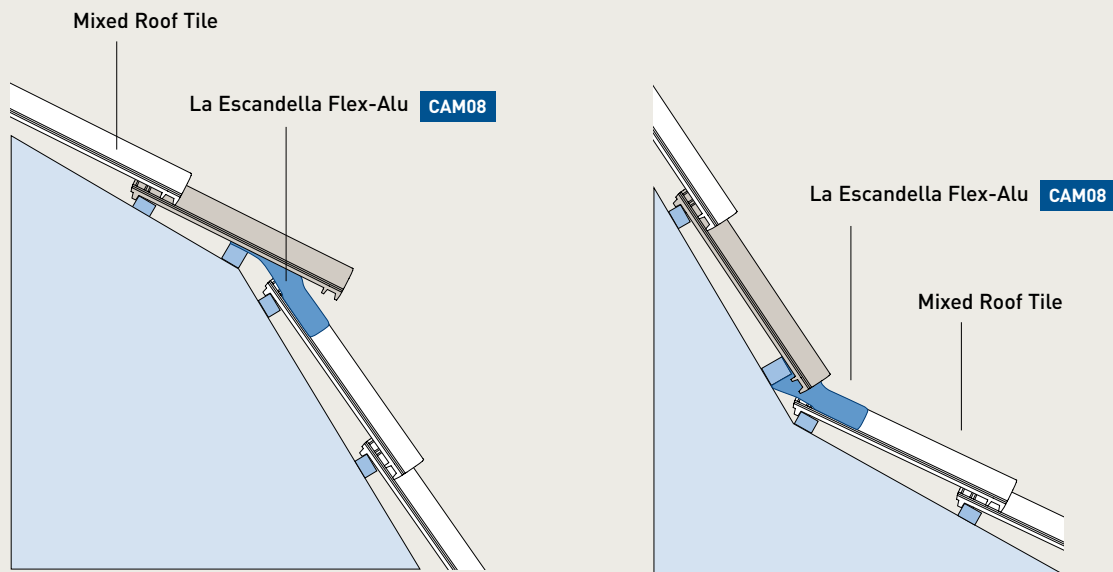

Note: The tiles at the change of slope must be fixed to the batten.
Where possible, the last course will be laid using full tiles, or otherwise Large Mixed Tiles with Q56.

Chimneys and ventilation conduits

TG-TP / TL / TI / TW / TN / TV

With chimneys and / or ventilation conduits, there are three intersections, which must correctly channel water and prevent its infiltration. For this flexible waterproofing membrane connection system (Flex-Alu) will be used, like for metal flashing which resolves the problem of drainage for the join with the conduit.

The lower join with the chimney or conduit will be treated like any horizontal upper join (see page 79).

Lateral joins will be treated like joins parallel to the maximum slope line (see page 81).

Where the field joins at the upper side of a vertical conduit, the solution is to place a gutter made of an impermeable or metallic membrane which will collect the water that arrives at this intersected, channelling it to the sides.

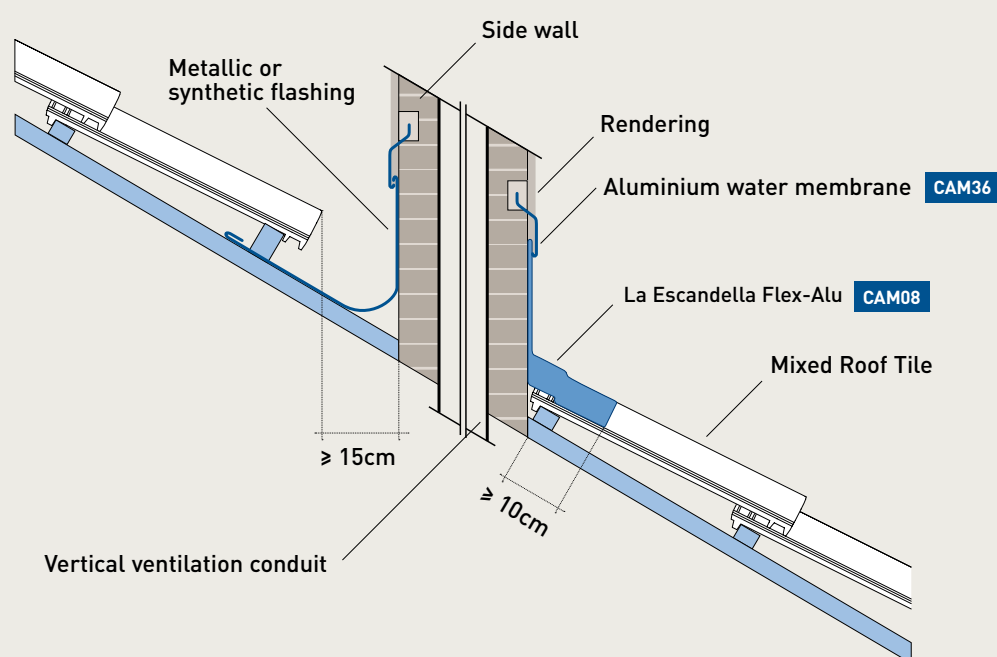

Roof's windows and skylights

TG-TP / TL / TI / TW / TN / TV

The perimeter zones of the field in contact with dormer or skylight frames will be made watertight so as to channel the water down to the lower parts of the field.

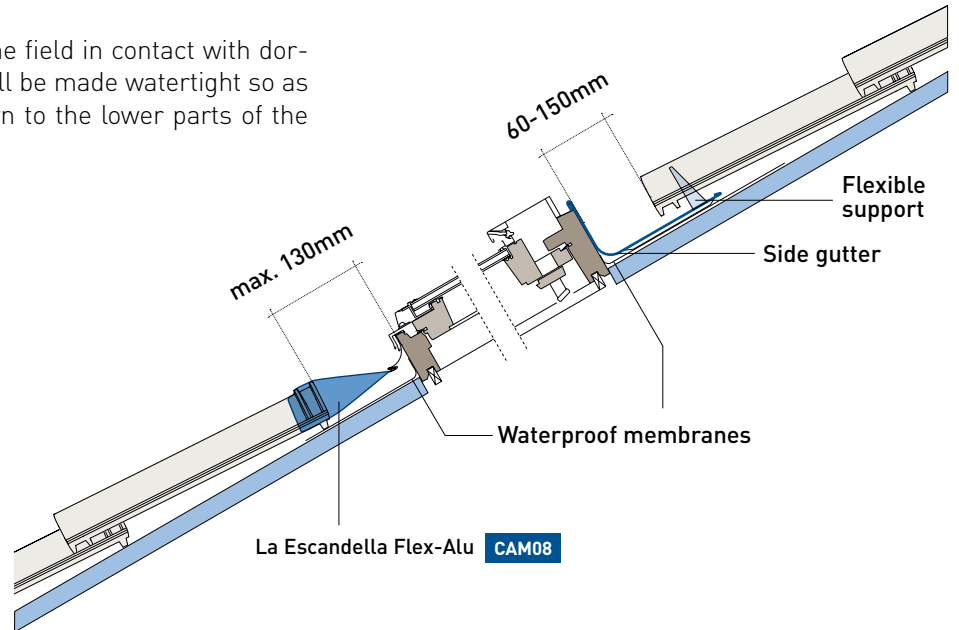

LONGITUDINAL SECTION

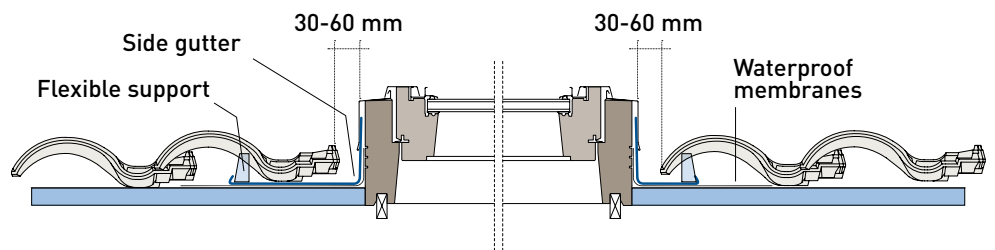

TRANSVERSAL SECTION

BIRD VIEW

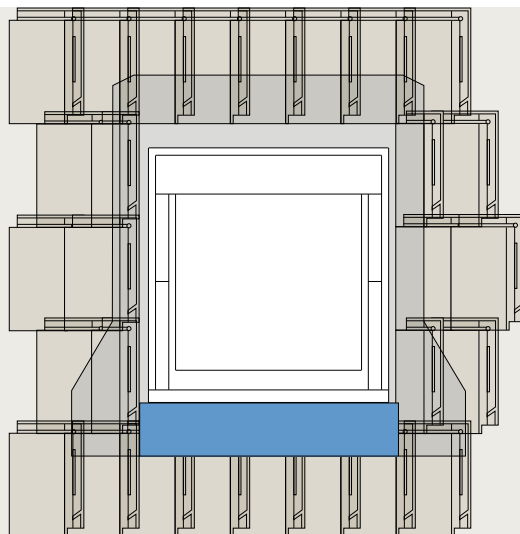

Other

Chimney Support installation. Chimney Kit TG-TP

When laying the components “16cm Chimney Support” for Large Mixed Tiles (**Q47**) and Small Mixed Tiles (**Q48**), a **half tile and a ventilation tile** must imperatively be used. Consequently:

- The **Q47** requires the **Q19** (Large Mixed Ventilation Tile) and the **Q16** (Large Mixed Half Tile).
- The **Q48** requires the **Q20** (Small Mixed Ventilation Tile) and the **Q17** (Small Mixed Half Tile).

A Metal Grid will be laid, covering the hole where the half tile meets the ventilation tile and the chimney support.



La Escandella provides a KIT which includes all the pieces needed for installing the **Q50** Chimney with both chimney supports (Large and Small Mixed), delivered in one case.

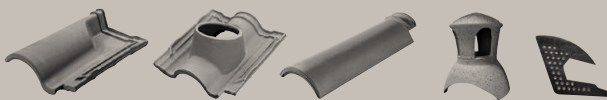

Large Mixed 160mm chimney kit:
Includes: Q19, Q47, Q50, Q16 and grid.

Small Mixed 160mm chimney kit:
Includes: Q20, Q48, Q50, Q17 and grid.

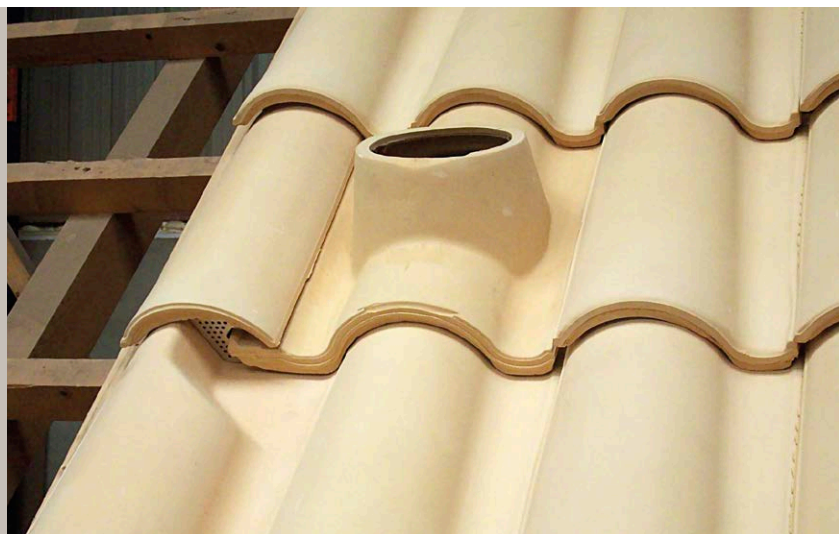

Curved Roof Tile

4.2



The curved tile, also called Channel or Mediterranean tile, has a characteristic cylindrical or conical upper plane. They are roofing elements in the form of a gutter. Their design allows variable overlapping between pieces. Their edges may be parallel or conical.

The curved tile has two functions: as the channel (pan) tile, it collects rain water, channeling it to the edges of the building; as the cover tile, it fills the gap between the channels.

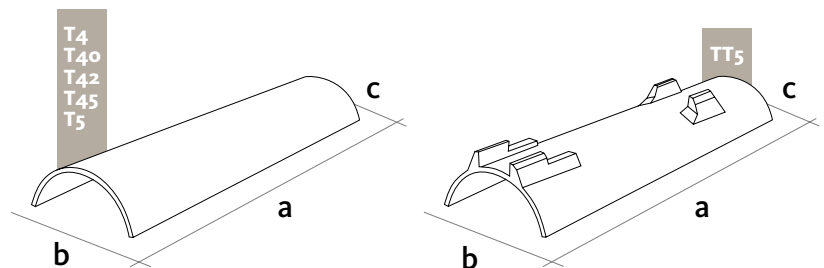

	Application Standard	Requirements	CURVED Roof Tile
Flexural Strength test	EN 538	Resistance > 1000N	Above
Impermeability	EN 539-1	Complies with level 1	Above
Frost Resistance	EN 539-2	Complies 150 cycles	Above

	TT5 Teton
Dimensions	a: 495 mm b: 220 mm c: 170 mm
Pieces per m² / ml	9 / 2,4
Weight piece	2.800 gr

GUARANTEE
35 YEARS

Colours and Textures

A variety of colours and textures allow accurate imitation of aged tiles with the guarantee of modern tiles

Higher Resistance

The composition of the clay and its perfect design, allow higher flexion than the standards require

Great Versatility

For both the renovation / restoration of emblematic buildings as for the newer Buildings, the Curve tile offers a high quality finish and fine touch

High Water Impermeability

A selection of quality clays together with high temperature cooking grant the tile very low water absorption

Easy Installation

It combines the Curve's elegance, technique and perfect design. Its round edges allow a perfect fit, tile upon tile and better handling

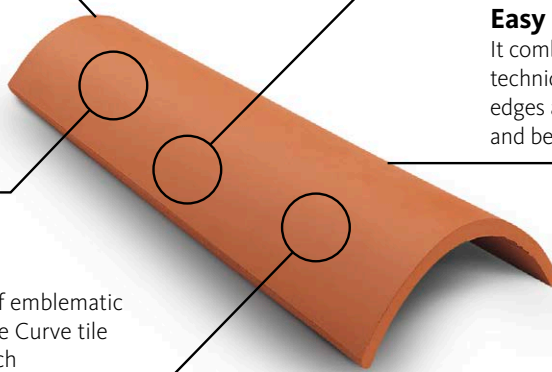

	T4 Red clay	T4 White clay	T40 Red clay	T42 Red clay	T45 Red clay	T5 Red clay	T5 White clay
Dimensions	a: 396 mm b: 182 mm c: 127 mm	a: 400 mm b: 185 mm c: 128 mm	a: 400 mm b: 160 mm c: 112 mm	a: 400 mm b: 220 mm c: 180 mm	a: 450 mm b: 220 mm c: 160 mm	a: 500 mm b: 220 mm c: 163 mm	a: 500 mm b: 220 mm c: 168 mm
Pieces per m² / ml	28 / 3	28 / 3	34 / 4	11,2* / 3	22,7 / 2,7	18 / 2,4**	18 / 2,4**
Weight piece	1.600 gr	1.550 gr	1.250 gr	1.800 gr	2.000 gr	2.550 gr	2.300 gr

* T42 on plate - Piece/m² : 12.7 to 15.2
** 70mm overlapping



Test of frost resistance



Impermeability test



Flexural strength test

Note: T4R and T5R tiles have the NF label of compliance with French and European standards. The T5R has the ICC-ES and Miami Dade labels.

Accessories

The special parts for ceramic roofs are made of the same material as the tiles, and are made to deal with special cases or discontinuous points of the roof.

These parts are essential for finishing particular spots where standard tiles do not join perfectly, making sure the roof is waterproof, uniform and aesthetically pleasing.

Below is a general scheme of a roof, showing various of these particular points and the special parts used to deal with them.

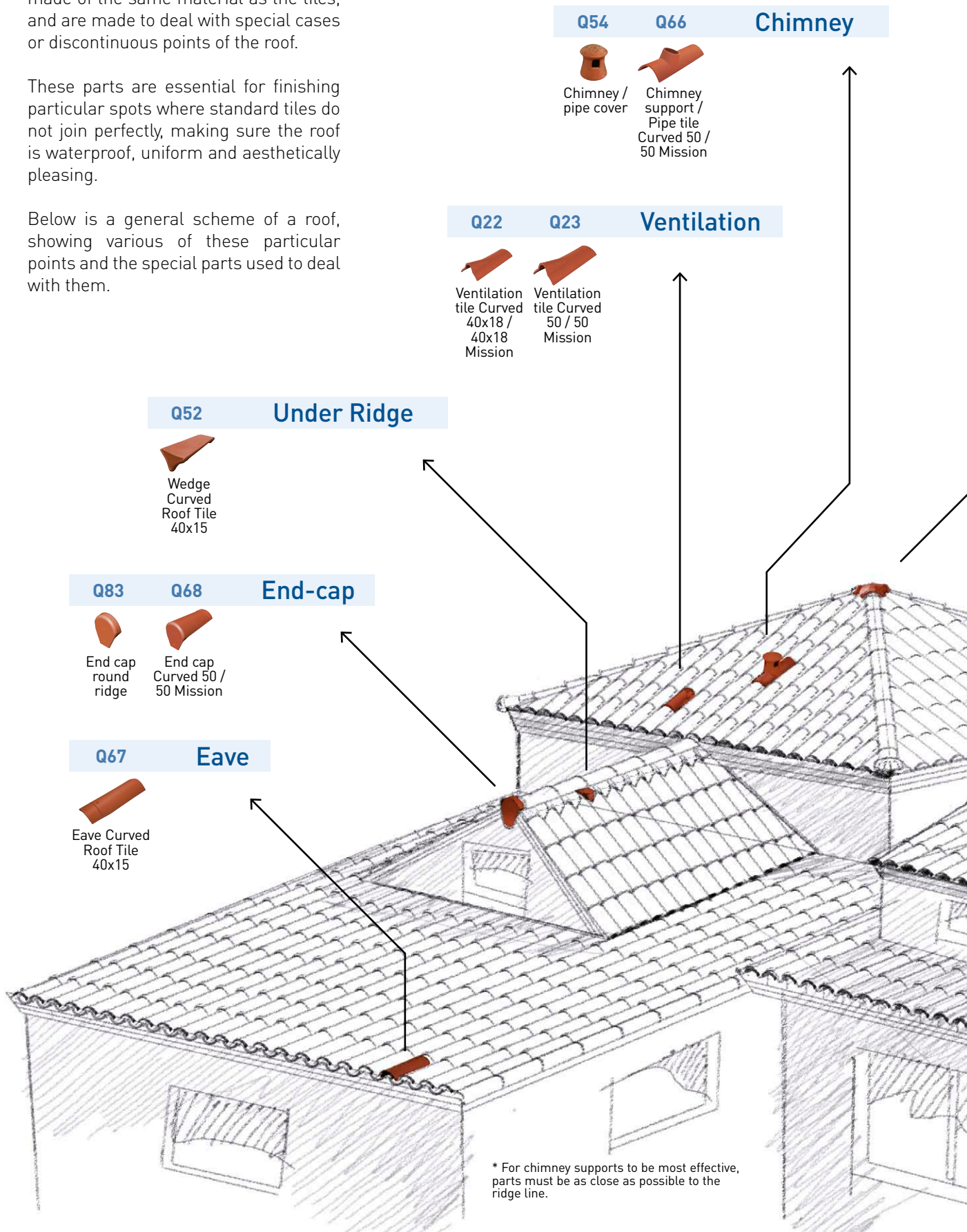

* For chimney supports to be most effective, parts must be as close as possible to the ridge line.

Joins

Q44



Round 3 way ridge

Q45



Round 4 way ridge

Q55



Round 3 way ridge female

Ridges

Q02



Round ridge / Hip

Other accessories

Q04



Round ridge end / Hip starter

Q69



Ridge end Curved 50 / 50 Mission

Side courses

Q12



Round left side course / rake

Q13



Round right side course / rake

Decorations

Q57



Acorn

Q28



Small piruli

Q29



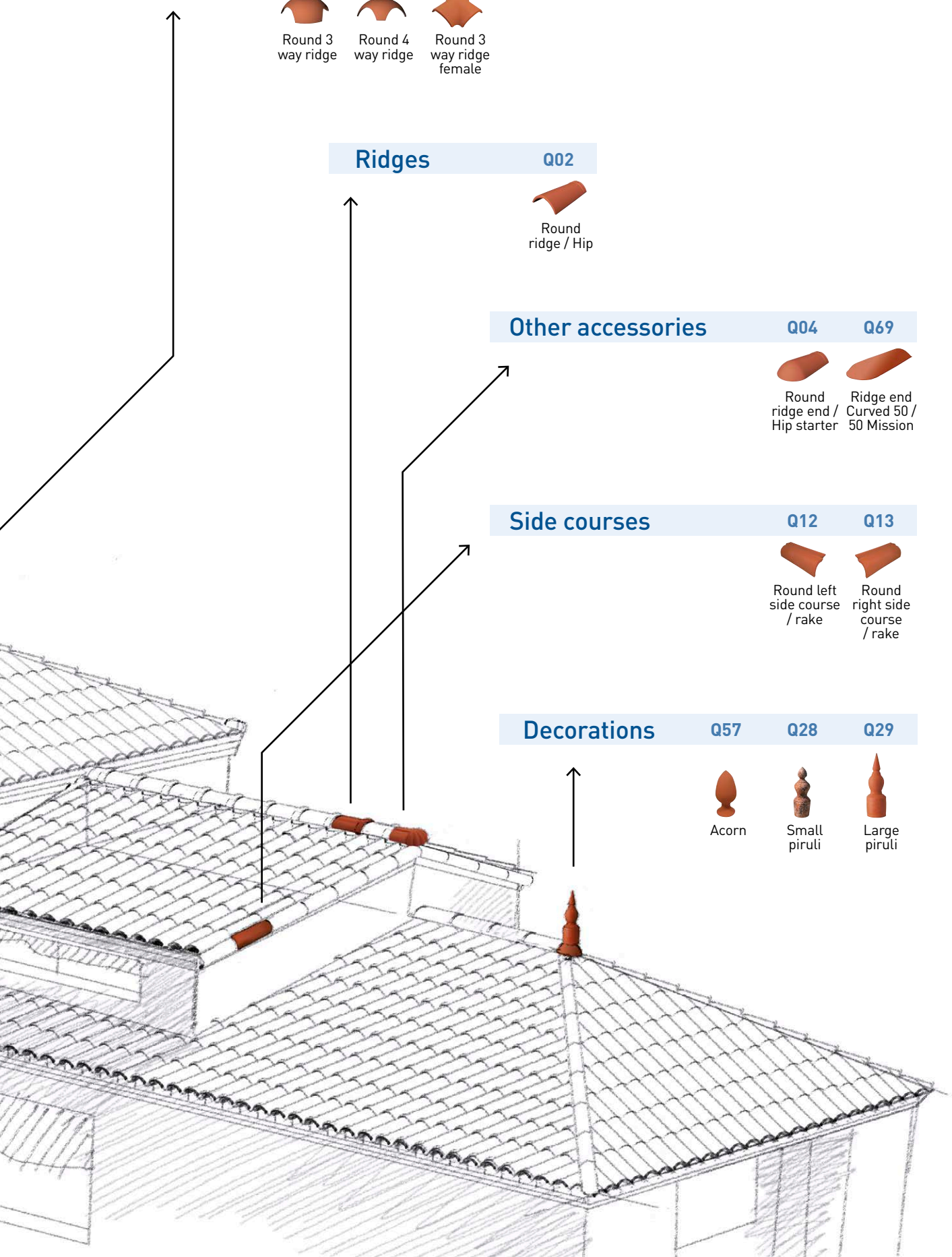

Large piruli

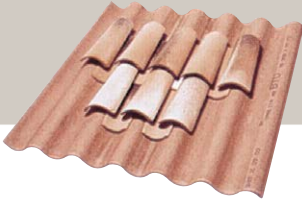

Underlayment support

The fibercement panels or sheets act as a support for the tiles, carrying out the function of a secondary cover which guarantees that the roof is watertight in case the slope or other requirements are not met.

Curved Roof Tile	T50	T45	T40X18	T42	T40X15
Corrugated Roofing sheets	Mixed profiles with a width tapering from 18cm to 22cm				Granonda profile- curved- with a width tapering from 12cm to 16cm
	M0220 M0201				M0204 M0205 M0206 M0207 M0208 

Fixation Systems

The manner in which roof tiles are installed makes them a highly effective water shedding assembly that affords years of service and protection. The effectiveness of a tile roof system as a weather resistant assembly however depends on the proper installation of all the tile roof components, and installing them properly is critical to the performance of the installed system.

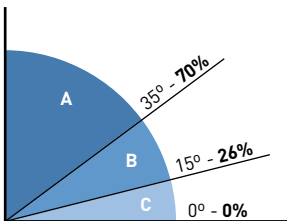

- A:** Every tile (pan and cover) should be securely fastened (nailed, screwed, clipped, so on).
- B:** All Channel (Pan) tiles must be fixed; cover tiles shall be fixed every 5 rows.
- C:** La Escandella recommended minimum slope requirement is 32%.

Note: The Locking Function is performed by the metal clamps / hooks, whereas the polyurethane foam acts only as a positioner.

CAM27 | Round ridge tile hook for Q02 ridge



CAM15 | Metal Clip For curved tile 50 (14 cm)

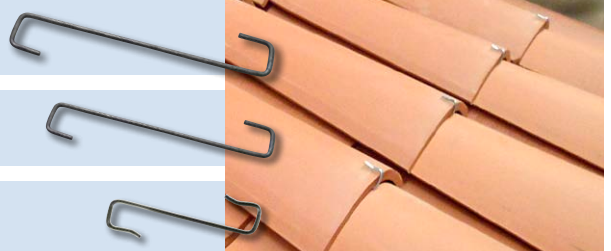

CAM61 | Metal Clip For curved tile 50 (17 cm)

CAM25 | Metal Clip For curved tile 40 (7,2 cm)

Laid method

Longitudinal fit

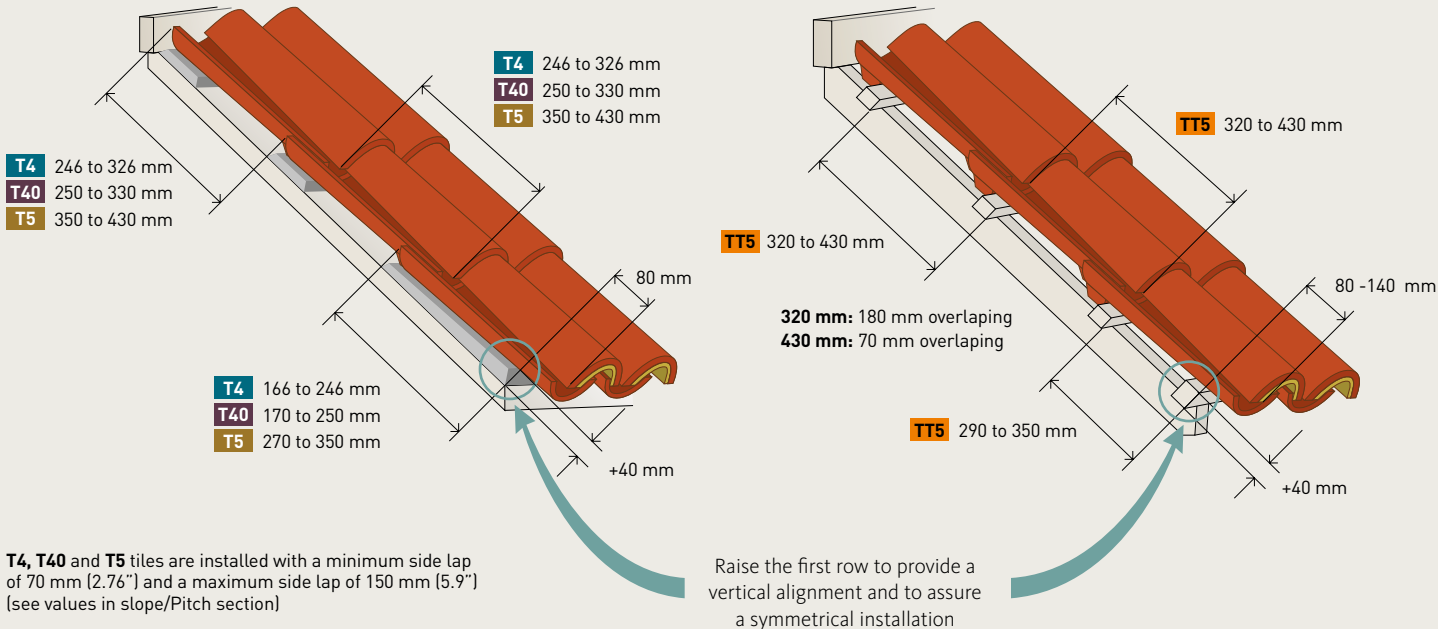

Transversal fit

Mortar fixing of clay roofing tiles

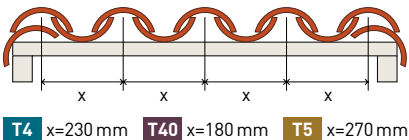

Fibre cement corrugated sheets fixing - Escandella (pre-engineered roof system)

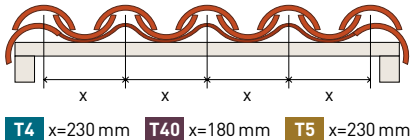

Teton (Barrel nose) tile fixing

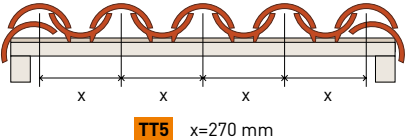

Installation of Curved Tile 50 on vertical batten (parallel with the maximum slope line)

The battens are placed at a distance of 240-270mm (between the inside and outside edges of the batten) and the half-way point between them is marked, 120-135mm. The line is marked on the supporting layer and the tile that will go from the channel is nailed to the continuous support, leaving the desired gap. In these conditions the distance from centre to centre between the tiles will be 240-270mm.

Pre-perforated tiles can be used for fixation to the covering, using wooden battens and continuous support for this.



The gap between the tiles will be 20-50mm

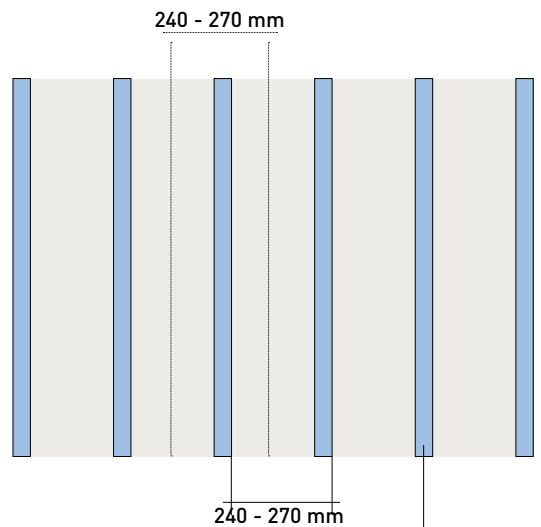

The batten used for the calculation is 40mm wide

To improve the fastening of the tile it can be screwed on and clipped, however, the clip imposes a limit of an overlap of 140mm.

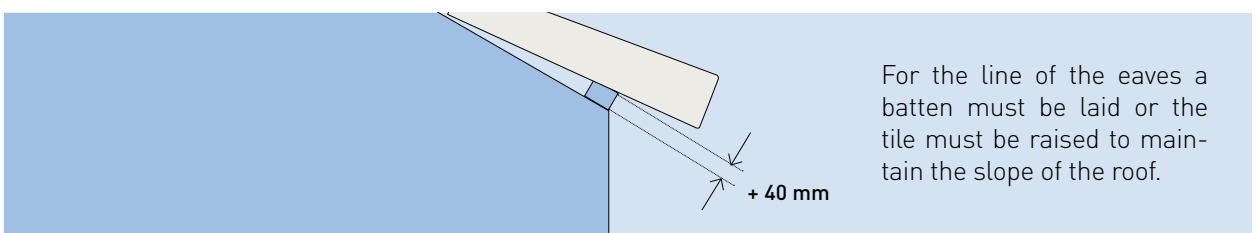

For the line of the eaves a batten must be laid or the tile must be raised to maintain the slope of the roof.

Installation of Curved Tile 50 with Teton (Barrel nose) tile

The Teton tile is always laid on battens, which the flange (or nose) sits on, enabling better and faster fixing.

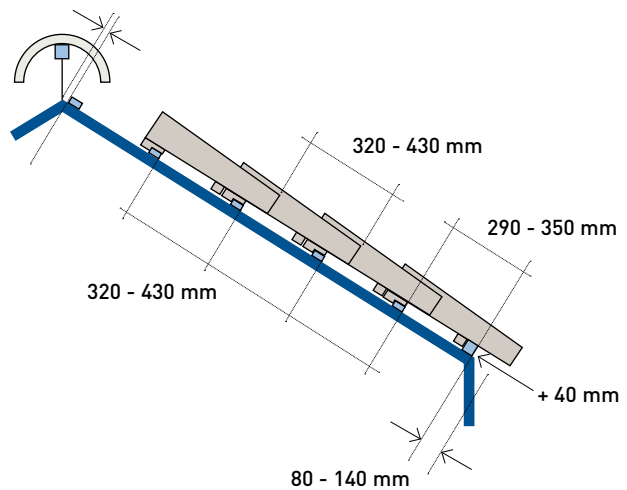

For transversal laying, spacing to ensure that the T5 pan tile meets the measurements defined in the norms of the destination country is accounted for.

Installation of Curved Tile 50 with corrugated sheeting

For the curved tile 50 a 230mm ridge width will be used. The minimum required overlap is always 70mm.

When using corrugated sheeting, it will not be necessary to lay the cut curved tile under the first eave tiles, since it makes a difference in the closure of the tiles.

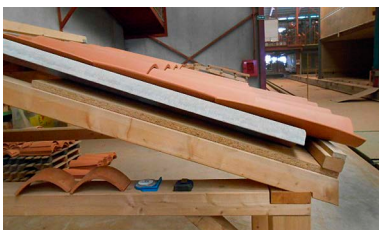

Installation details

Eave

The first thing to be considered when laying the eaves is that both the sheeting and the cap tile must overhang by a minimum of 5cm.

The canal tiles will be laid the whole length of the eaves, and fastened with polyurethane foam.

Subsequently, the cover tiles will be laid, buttressing the wide end with a small piece of the narrow end, to prevent slumping.

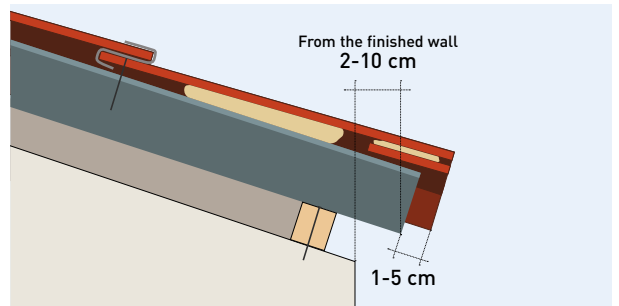
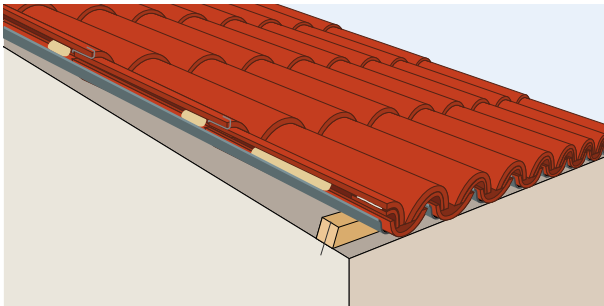
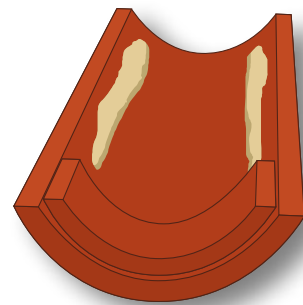

Note: or the 40x15 Curved Tile the Q67 should be used, or Curved Tile eaves.

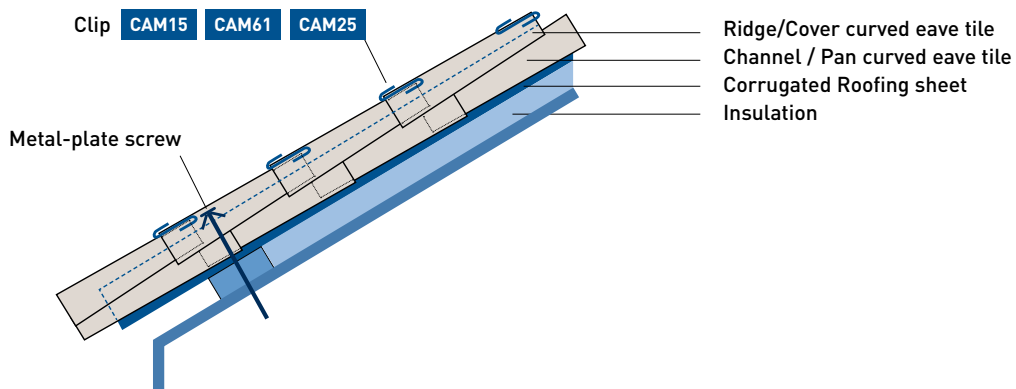

Side courses

T5 | Round Side Course Q12 Q13

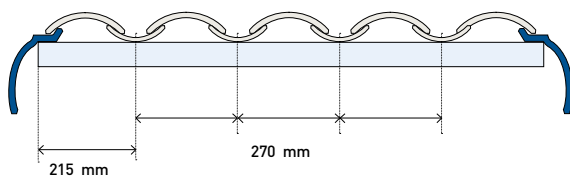

The back tile which lies in the line of the curved lateral end tile will sit slightly lower than the rest of the curved tiles on the ridge line.

Ridge

When laying the roof the ridge tiles must be laid facing away from the dominant winds and rain.

All the curved tiles of the final horizontal row must be fixed, either on the battens or directly to the sheeting with polyurethane foam.

A waterproof ridge band CAM01 is laid over the ridge channel tiles. This will be covered by the ridge tiles of the final course, which will be fixed with screws and foam.

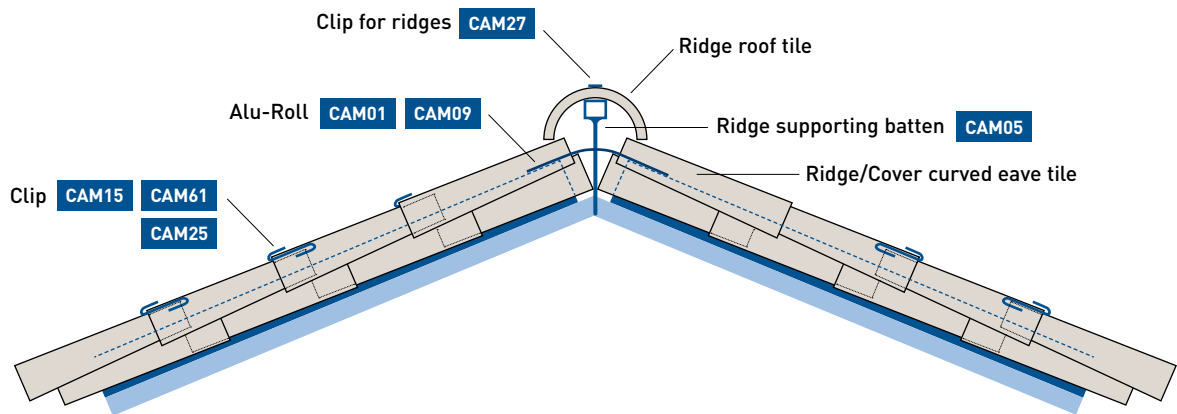

The ridge tiles will be fixed to the sheet, together with the clip that fastens one tile to the next, using self-drilling screws and a line of foam.

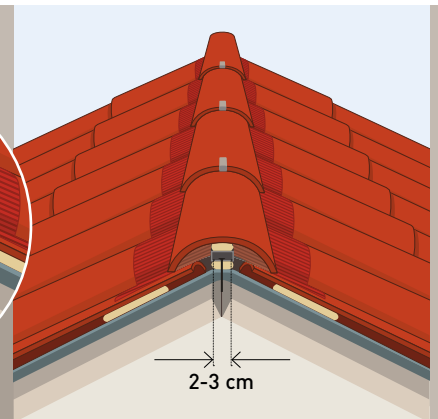
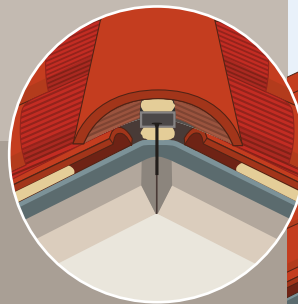
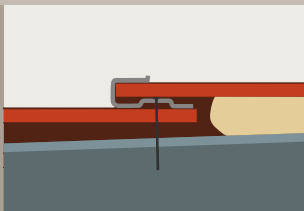

Valley

The roof parts, fibercement panels + tiles, must overhang the valley by at least 5cm.

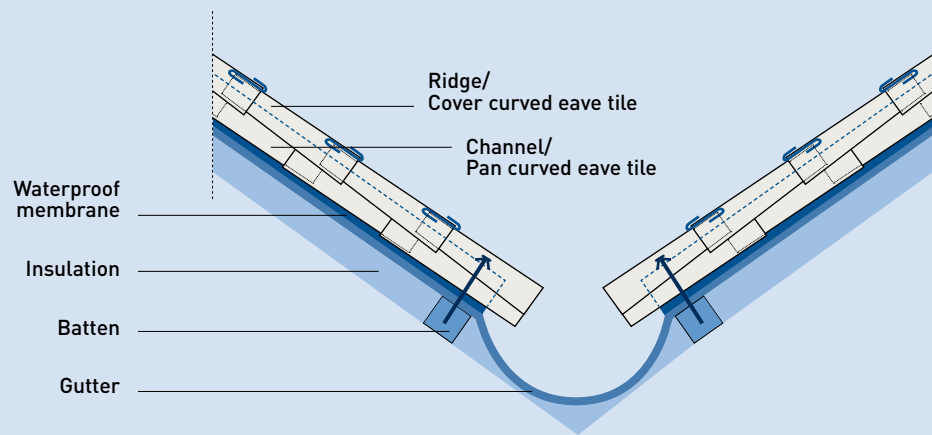
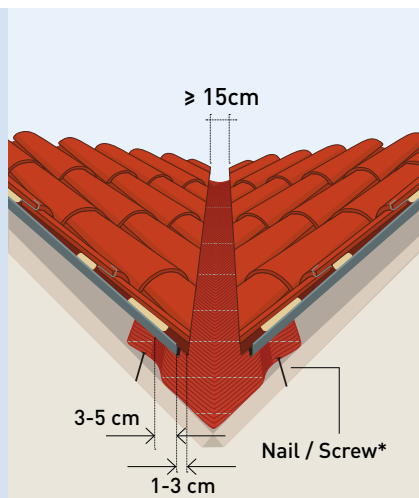

*Nail (concrete frame or joists)
Screw (wood)
Screw (metal joists)

Hip

Installation follows the same specifications as the ridge.

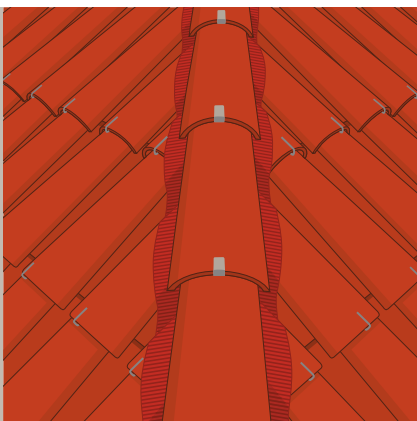

Vertical Walls

Where gables intersect with vertical walls, a protective element will be placed, which will be sealed to the vertical wall with rubber, to ensure it is watertight.

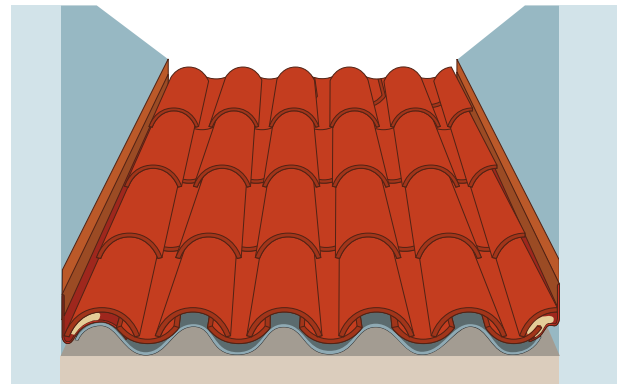
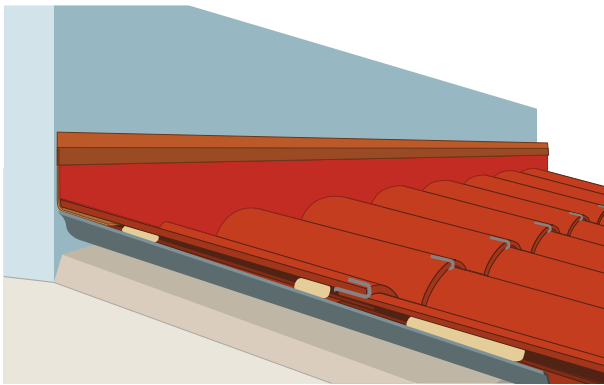

Pitch change

When there is a change of slope on the field, the overhang between the fibre cement panels must be respected, to ensure the zone is watertight.

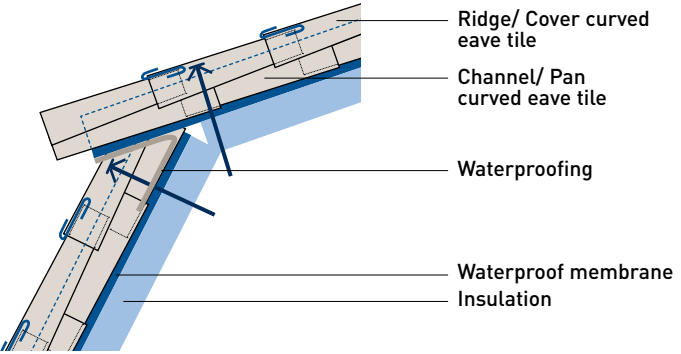
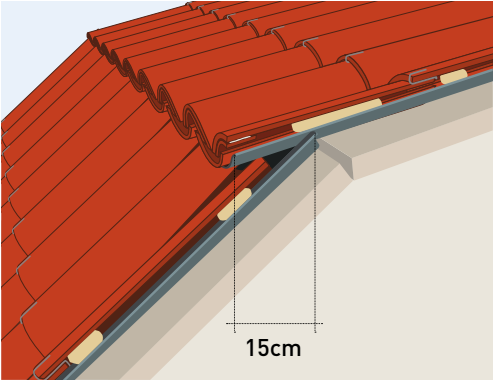
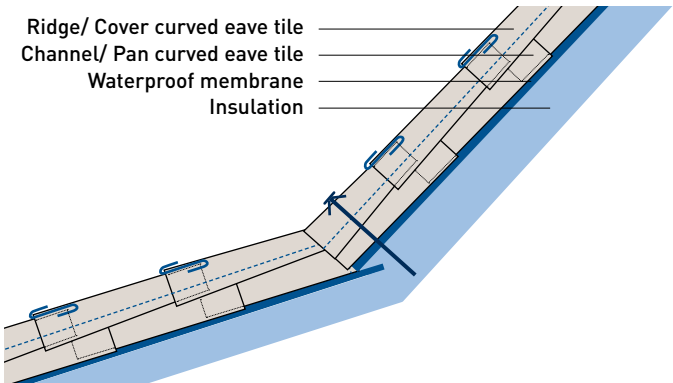
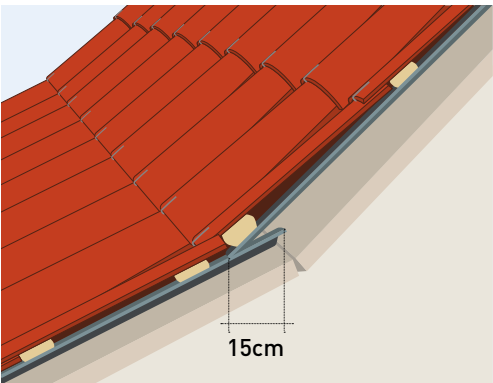

Chimneys and ventilation ducts

With chimneys and / or ventilation conduits, there are three intersections, which must correctly channel water and prevent its infiltration. For this a flexible waterproofing membrane connection system (Flex-Alu) will be used, like for metal flashing which resolves the problem of drainage for the join with the conduit.

The lower join with the chimney or conduit will be treated like any horizontal upper join.

Lateral joins will be treated like joins parallel to the maximum slope line.

Where the field joins at the upper side of a vertical conduit, the solution is to place a gutter made of an impermeable or metallic membrane which will collect the water that arrives at this intersection, channelling it to the sides.

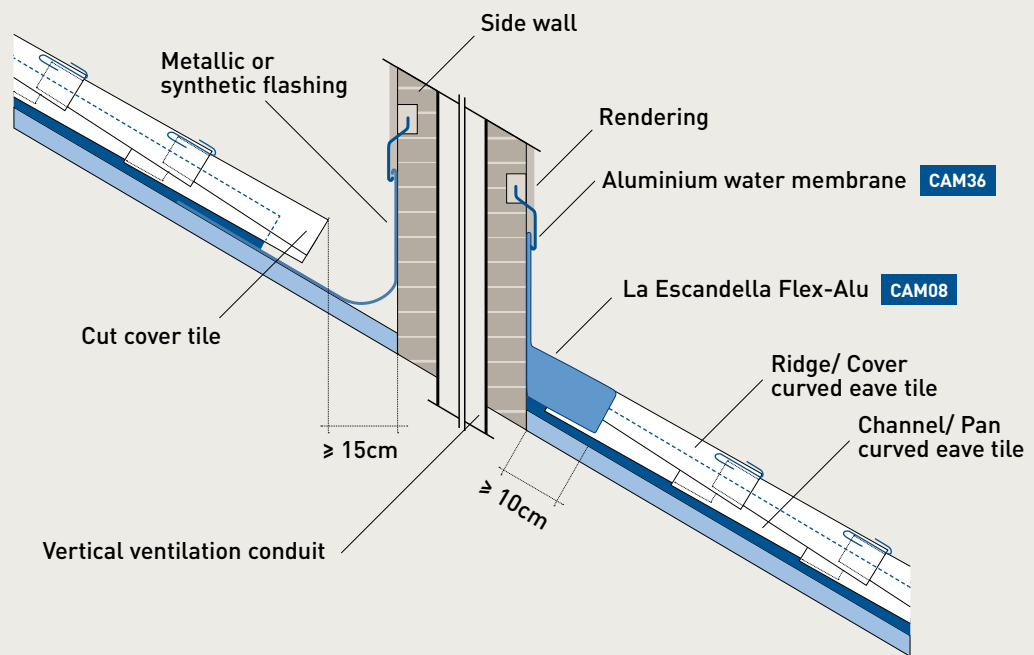

Roof's window and skylights

The perimeter zones of the field in contact with dormer or skylight frames will be made watertight so as to channel the water down to the lower parts of the gable.

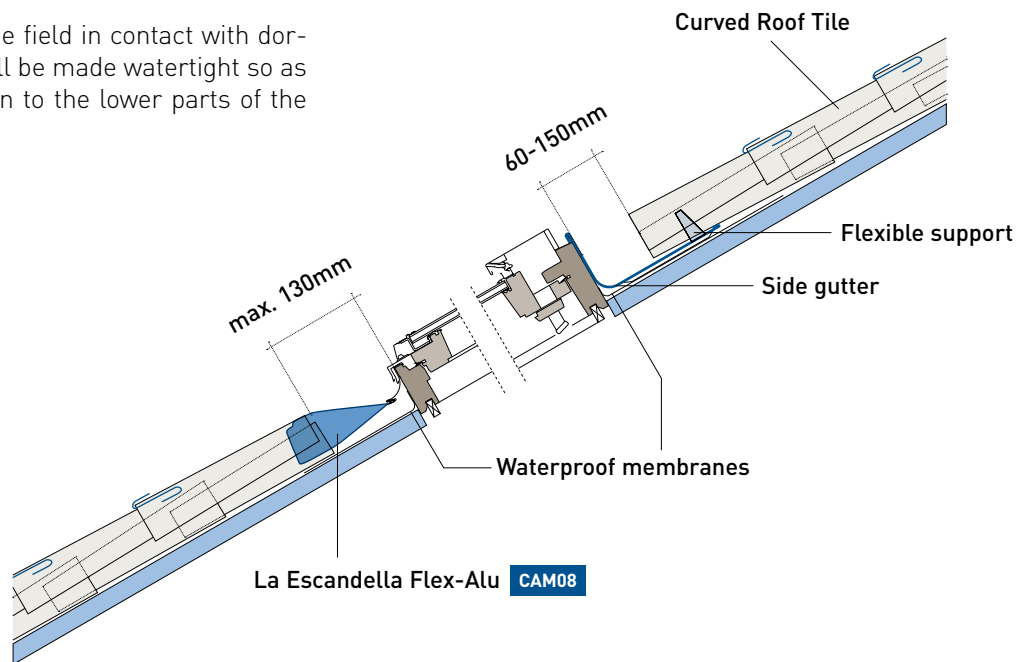

LONGITUDINAL SECTION

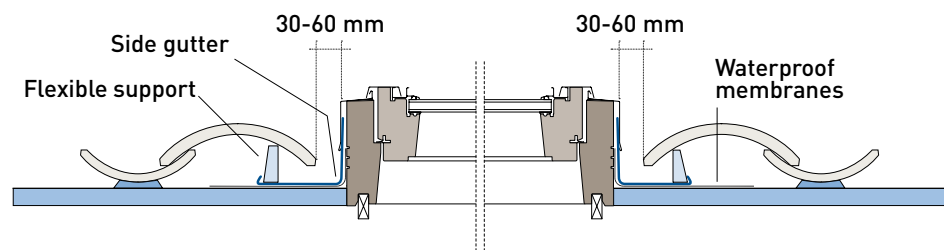





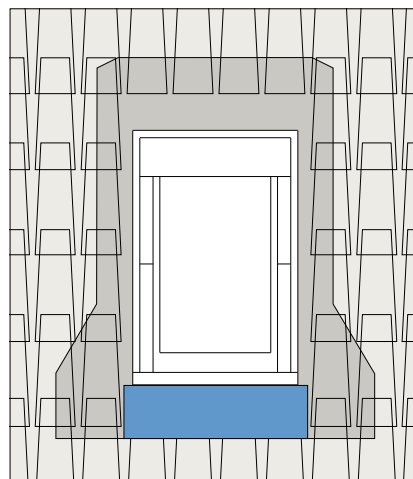











































TRANSVERSAL SECTION

BIRD VIEW



Summary of accessories by format

	Ridge					Ridge accessories					Side courses/ Rake	Half Tile
	Normal	Round	Pyramid	Atica	Angular	Normal	Round	Pyramid	Atica	Angular		
INNOVA ROOF TILE	Q01*K 	Q02*K 		Q90*K 	Q120*K 	Q03*K 	Q04*K 		Q109*K 	Q122*K 	Q115*K 	Q119*K 
				Q110*K 							Q116*K 	
VIENNA ROOF TILE	Q01*K 	Q02*K 		Q90*K 	Q120*K 	Q03*K 	Q04*K 		Q109*K 	Q122*K 	Q115*K 	
				Q110*K 							Q116*K 	
PLANUM ROOF TILE		Q02*K 	Q91*K 	Q90*K 	Q120*K 		Q04*K 	Q93*K 	Q109*K 	Q122*K 	Q88*K 	Q85*K 
				Q110*K 							Q89*K 	
VISUM3 ROOF TILE		Q02*K 	Q91*K 	Q90*K 	Q120*K 		Q04*K 	Q93*K 	Q109*K 	Q122*K 	Q99*K 	Q100*K 
				Q110*K 							Q101*K 	Q102*K 

H-Selection

End-cap				Hip accessories					Ventilation roof tile	Chimney Support	Rafter Chimney
Normal	Round	Pyramid	Angular	Normal	Round	Pyramid	Atica	Angular			
Q05*K	Q83*K		Q124*K	Q44*K			Q111*K	Q123*K	Q117*K	Q118*K	Q121*K
				Q45*K							
				Q55*K							
Q05*K	Q83*K		Q124*K	Q44*K			Q111*K	Q123*K	Q117*K	Q118*K	Q121*K
				Q45*K							
				Q55*K							
Q83*K	Q92*K	Q124*K		Q44*K	Q94*K	Q111*K	Q123*K	Q86*K			Q87*K
				Q45*K							
				Q55*K							
Q83*K	Q92*K	Q124*K		Q44*K	Q94*K	Q111*K	Q123*K	Q96*K			Q97*K
				Q45*K							
				Q55*K							



Roofing Components

05



Roofing components

ROOF VAPOUR BARRIER

CAM21 / CAM52 / CAM65 / CAM53 / CAM 54
Waterproof membrane

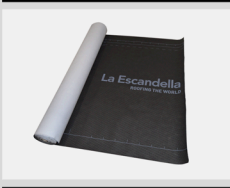

CAM55 / CAM56
Condensation barrier membrane

CAM31 / CAM32 / CAM39
Adhesive tapes

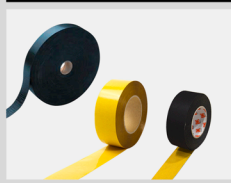

CONNECTION SYSTEMS

CAM08 / CAMF8
Flex-Alu

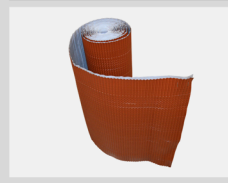

Width: Several sizes
Colours: Red, paja, brown, black.

CAM36
Aluminium water membrane



Colours: Red, brown, black.

VENTILATION SYSTEMS FOR THE EAVE

CAM13
Gutter-Run In-Sheet Alu



Width: 230mm / 9.05"
Colours: Red.

CAM14 / CAM16 / CAM58
Eaves Ventilation Comb

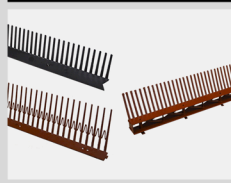

Width: Several sizes
Colours: Red, brown, black.

CAM33 / CAM34
Eave grating



Width: 10cm / 15cm // 3.94" / 5.9"
Colours: Red, black.

CAM38
Metal bird spikes

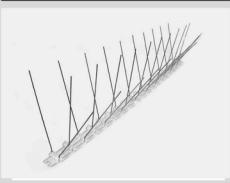

Width: 1m

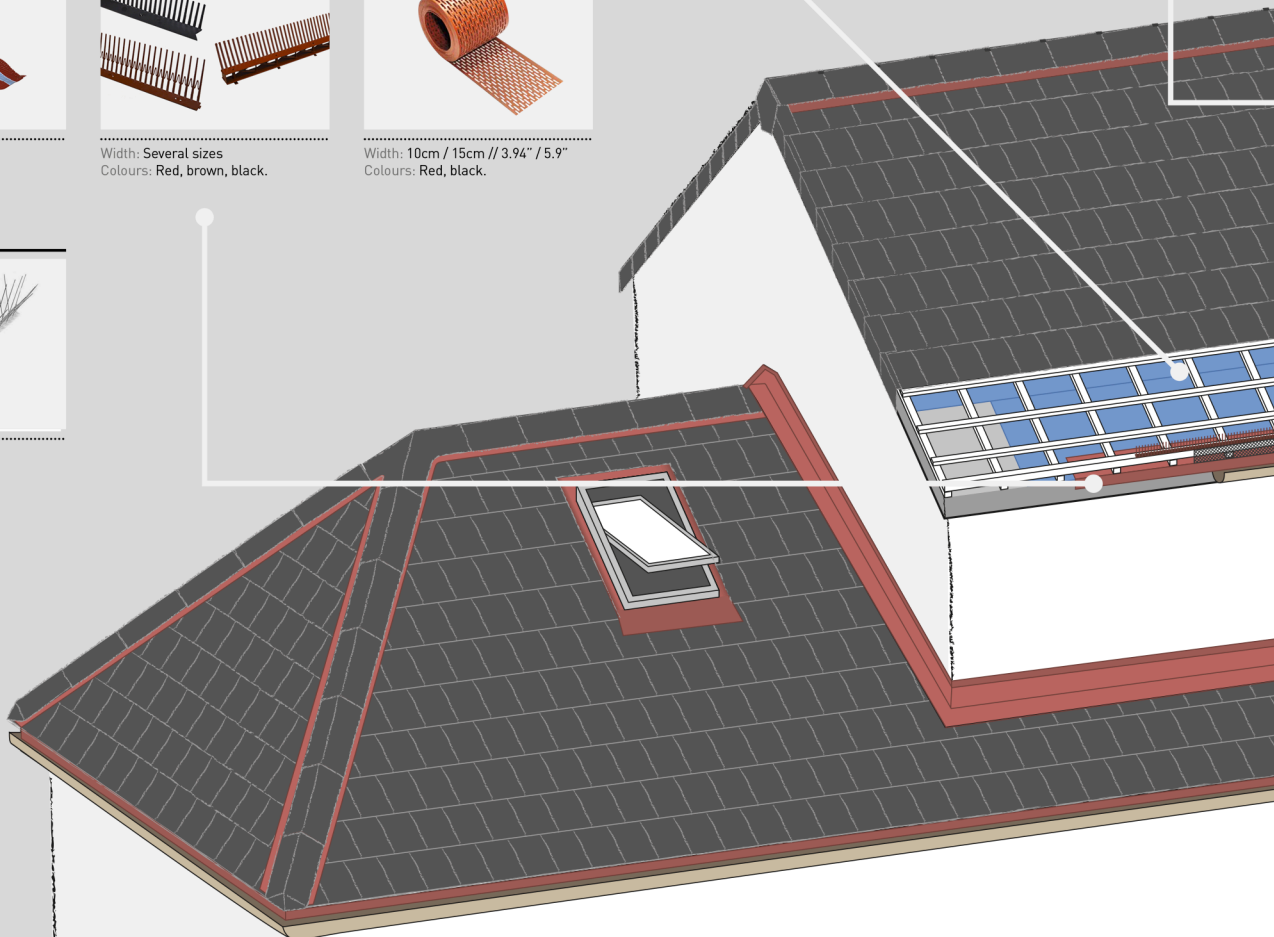

VENTILATION SYSTEMS FOR RIDGES AND ROOF HIP

LAYING SYSTEMS

CAM42 / CAM20
Batten



Material: Galvanized metal, PVC.

CAM07 / CAM27 / CAM10 / CAM70
Hooks and clips



CAM59 / CAM62 / CAM 64
CAM61 / CAM15 / CAM 25

CAM01 / CAMF1 / CAMF950
Alu-Roll Aluminium



Width: Several sizes
Colours: Red, paja, brown, black.

CAM09 / CAMF9
Alu-Roll Membrane



Width: Several sizes
Colours: Red, brown, black.

CAM05 / CAM010 / CAM51
Batten Brackets



Width: 40 / 50 mm // 1.57" / 1.97"
Material: Galvanized steel.

VENTILATION SYSTEMS FOR THE VALLEYS

CAM18
Alu-Valley Tape

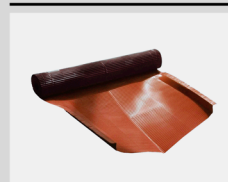

Colours: Red, brown, black.

CAM37
Sealing Wedge



Colours: Red.

CM0500 / CM0501 / CM0502
Repairer paint pot

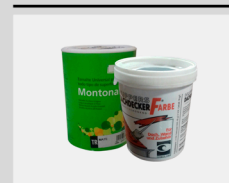

Colours: Galaxy, Slate, Brown.

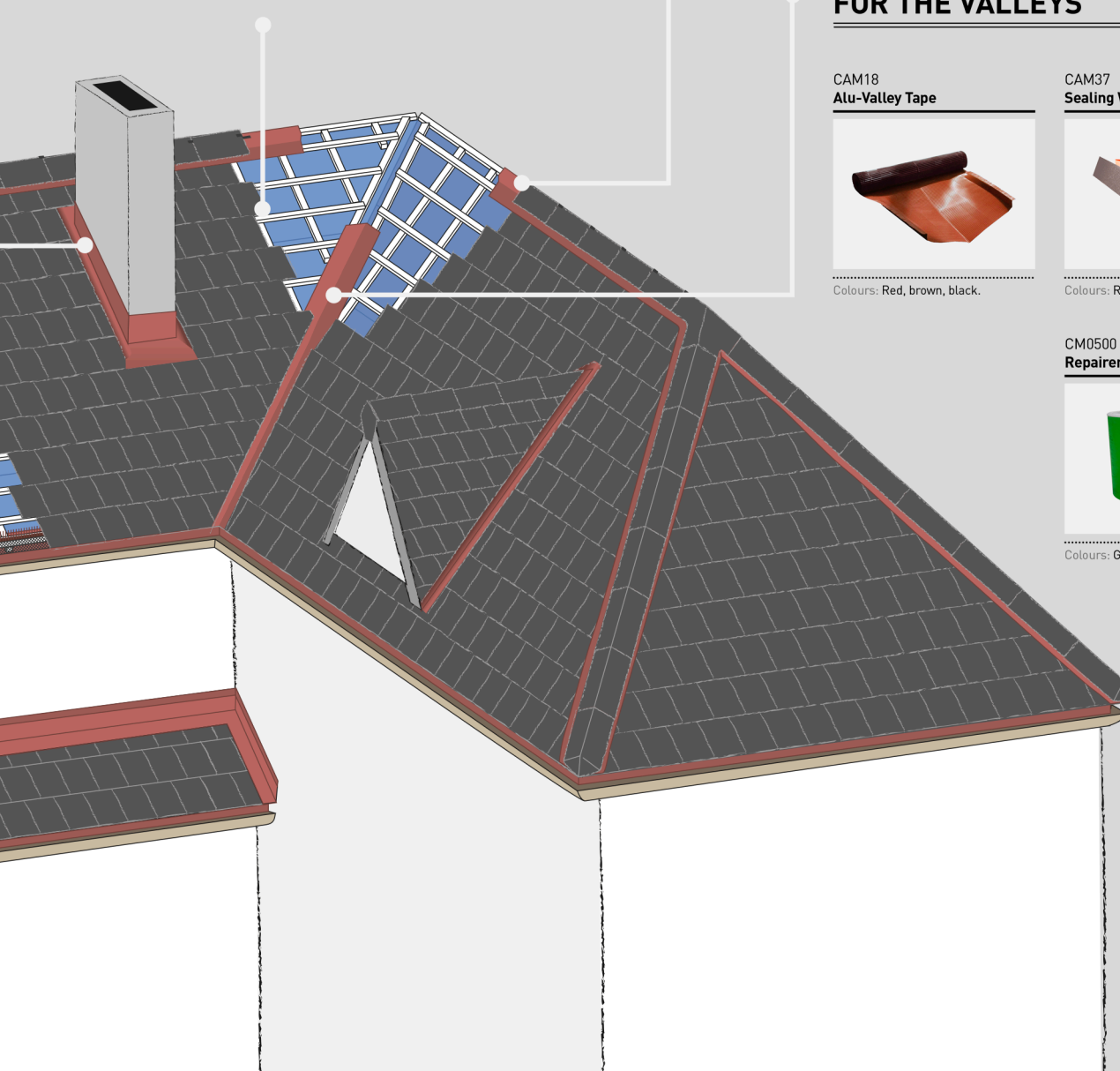

Waterproofing



ALU-ROLL WITH MICRO CUT

CAM01 / CAMF1

Rolls: 5 meters.

Dimensions: 31 cm / 40 cm width.

Colors: Red, Brown, Black, Paja.

Versatile aluminium mesh to be used under the ridges, designed to allow the air flow, and to protect against the entry of birds and rodents.

High UV and aging resistance.

Always apply on clean and dry surfaces.



ALU-ROLL MEMBRANE

CAM09 / CAMF9 / CAMF950

Rolls: 5 m. / 5 m. / 50 m.

Dimensions: 31 / 39 / 39 cm width.

Colors: Red, Brown, Black.

Side aluminium strips with internal covering of an adhesive band, connected to a polypropylene open air mesh.

Waterproof, each side ensuring a free passage of 145 cm².

High UV and aging resistance.

Always apply on clean and dry surfaces.

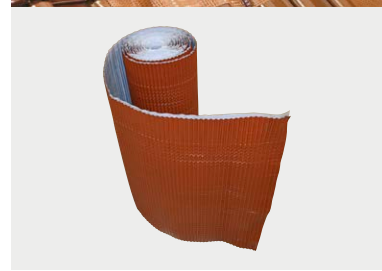

FLEX ALU

CAM08 / CAMF8

Rolls: 5 meters.

Dimensions: 31 cm / 40 cm width.

Colors: Red, Brown, Black, Paja.

Pleated band to ensure maximum adaptability and flexibility when applying. Flex-Alu is ideal for the waterproofing and sealing of joints on the roof: garrets, chimneys, walls, skylights, windows, ...

High UV and aging resistance.

Always apply on clean and dry surfaces.



ALUMINIUM WATER MEMBRANE

CAM36

Dimensions: 8 cm width x 2 meters large.

Colors: Red, Brown, Black.

Prelacquered sheet in 3 different Colors to be used for side finishing of the Flex-Alu bands for vertical joints and chimneys.



ALU SHEET FOR DRAINAGE OF GUTTERS

CAM13
 Rolls: 5 meters.
 Dimensions: 23 cm width.
 Colors: Red.

Versatile aluminium foil to be used on the eaves of the roof, to ensure a correct waterproofing in the eaves region and drainage towards the gutter.

High UV and aging resistance.

Always apply on clean and dry surfaces.



MICRO-PERFORATED VALLEY TAPE

CAM18
 Rolls: 5 meters.
 Dimensions: 50 cm width.
 Colors: Red, Brown, Black.

Aluminium foil used on the valleys for collecting water from the pitch, ensuring a correct waterproofing.

High UV and aging resistance.

Always apply on clean and dry surfaces.



UNDER RIDGE KIT WITH BATTEN SUPPORTS

CAM50
 Dimensions: 1 meter long (Side-strips: 14cms each)
 Colors: Red.

Rigid under-ridge sheet with galvanized steel dome and aluminium strips. It is lightweight and can be adapted to any type of ridge.

The air outlet (100 cm²/m each side) ensures a perfect ventilation of the roof. The ridge sheet and 2 batten supports are included.



SEALING WEDGE

CAM37
 Dimensions: 60mm width x 1m long.
 Colors: Red.



PAINT POTS

CM0500 / CM0501 / CM0502
 Capacity: 750ml. Pot
 Colors: Galaxy, Slate, Brown.

Special paint for tiles, used in the assembly of dark colored roofs, to increase the beauty of the red clay texture that are visible when cutting pieces during the installation of the valleys or other meeting points.

Ventilation



EAVES VENTILATION COMB SHIELD

CAM16 Mixed roof tile.
 Dimensions: 11 cm x 1 lm.
 Colors: Red, Black, Brown.
 CAM14 Flat roof tiles.
 Dimensions: 6 cm x 1 lm.
 Colors: Red, Black.

The bird stopper comb protects the under tile area from birds and rodents. It is installed with nails or screws directly on the first batten, the tile being overlapped. It allows the air flow in the eaves region.



EAVES VENTILATION COMB WITH BATTEN

CAM58 Flat roof tiles.
 Dimensions: 6 cm x 1 lm.
 Colors: Red, Black.

METAL BIRD SPIKES

CAM38
 Dimensions: 1 lm.

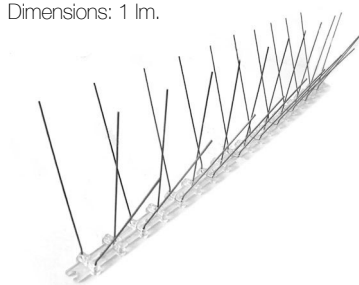

EAVE GRATING

CAM34
 Dimensions: 15 cm width, 5 mt. roll.
 Colors: Red.
 CAM33
 Dimensions: 10 cm width, 5/60 mt. roll.
 Colors: Red, Black.

It protects the open ventilation area in the eaves against the entry of birds and rodents. The holes allow the air flow to ensure a proper ventilation.

Waterproof membranes



WATERPROOF MEMBRANE

CAM65 / CAM21 / CAM52 / CAM53

Dimensions: 1.5 mt width, 75 m² roll.

Weight: 115 grs/m² / 135 grs/m² / 150 grs/m² / 180 grs/m².

Waterproof membrane with a high transpiration capacity and 3 overlapped and thermosealed layers. The weight is of 135 grs/m², 150 grs/m² and 180 grs/m² and allowing a high permeability to steam, while it is waterproof and protects against wind.



ADHESIVE TAPE FOR WATERPROOF MEMBRANE

CAM31: 1 side tape

Dimensions: 5 cm width, 20 mt roll.

Colors: Yellow.

CAM39: 2 sides tape

Dimensions: 4 cm width, 50 mt roll.

Colors: Yellow.

Polyethylene adhesive tape with reinforcing mesh covered with high resistance acrylic adhesive. Designed for bonding waterproof membranes in its overlapped area preventing the air and wind flow through the different layers.



NAIL UNDER TILE DRILLING

CAM32

Dimensions: 4 cm width, 30 mt roll.

Colors: Black.

Adhesive tape used between batten supports and waterproof membrane to prevent leakage where battens are nailed.



CONDENSATION BARRIER MEMBRANE

CAM55 / CAM56

Dimensions: 1.5 mt width, 75 m² roll.

Weight: 135 grs/m² / 150 grs/m².

Condensation barrier membrane with three overlapped and thermosealed layers. The weight is of 135grs/m² or 150 grs/m².



Fixation

RIDGE TILE HOOKS



Prelacquered aluminium hooks. The hooks are screwed onto the battens, the curved part encases the ridge tile and holds it in place; this procedure is repeated on the end of the next ridge tile, therefore causing the interlocking and stability required.

RIDGE TILE HOOK

CAM07
Installation witch Q01
Colors: Red.
Box 50 units.



ROUND RIDGE TILE HOOK

CAM27
Installation witch Q02
Colors: Red-Black-Brown.
Box 50 units.



PYRAMID RIDGE TILE HOOK

CAM10
Installation witch Q91- Q90
Colors: Red-Black.
Box 50 units.



ANGLE RIDGE TILE HOOK/CLIP

CAM70
Installation witch Q120
Colors: Red-Black.
Box 50 units.



CLIPS AND HOOKS



METAL CLIPS FOR CURVED ROOF TILE

Dry fixation system for curved tiles. It ensures its fixation and prevents tiles from lifting.

METAL CLIP FOR T5

CAM15 / CAM61
Dimensions: 14 cm / 17 cm long.
Colors: Galvanized.
Box: 400 units.



METAL CLIP FOR T40

CAM25
Dimensions: 7.2 cm long.
Colors: Galvanized.
Box: 1,000 units.



METAL CLIPS FOR H-SELECTION

Fixation system for H-Selection tiles. It ensures fixation and prevents lifting tiles wind. It is presented in the manner of installation or by subsection, either nailed to battens.

METAL HOOK/CLIP FOR WOODEN BATTEN TI-TV-TN-TW

CAM59
Installation: Wooden batten
38 x 27 mm, 30 x 40 mm.
Colors: Galvanized.
Box: 250 units.

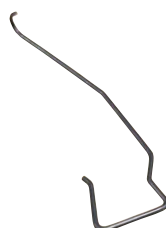

METAL CLIP CLIPPED WITH A BUMPER TI-TV-TN-TW

CAM64
Installation: Wooden batten
25x38 mm, 25x50 mm.
Colors: Galvanized.
Box: 500 units.



EAVE HOOK/CLIP

Dry fixation system for eaves in mixed and flat roof tiles. It ensures fixation and prevents lifting tiles wind.

CAM62
Instalación: Eave only.
Colors: Galvanized.
Box: 100 units.



RIDGE BATTEN SUPPORTS

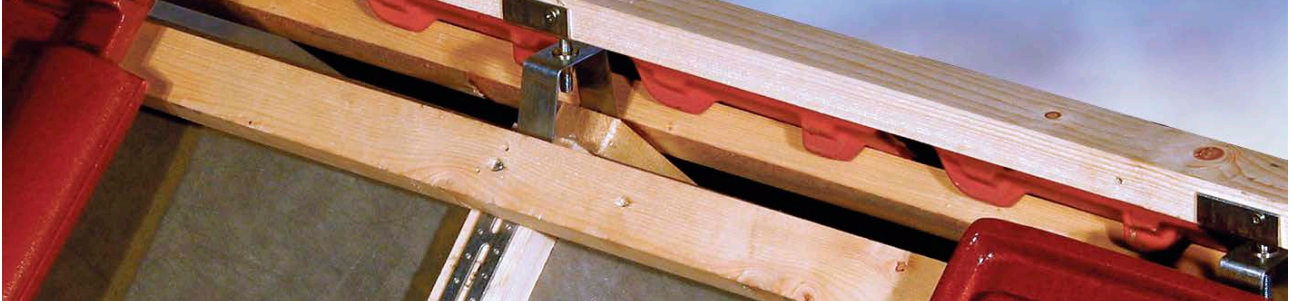

ADJUSTABLE RIDGE BATTEN V BRACKET
CAM010

Aluminium ridge supports for battens to be adapted to any rigid surface. Install with screws and nails, leaving 80 cm between fixation elements.

Dimensions:
For batten supports ≤ 4 cm width
Colors: Stainless steel



RIDGE BATTEN BRACKET WITH KNOCK IN SCREW
CAM05

Screwable batten support is directly installed on the wooden beam in the ridge to the height required, leaving 80 cm between each one.

Dimensions:
For batten supports ≤ 5 cm width
Colors: Stainless steel



RIDGE BATTEN Z BRACKET
CAM051

Aluminium ridge supports for battens to be adapted to any rigid surface. Install with screws and nails, leaving 80 cm between fixation elements.

Dimensions:
For batten supports ≤ 4 cm width
(18 cm for each bracket arm)
Colors: Stainless steel



BATTEN SUPPORTS



METAL BATTEN SUPPORT
CAM42

Dimensions: 2 cm x 3 cm x 2.10 mt.
(Omega wing: 1.5 cm)
Colors: Galvanized

PVC BATTEN SUPPORT
CAM20

Dimensions: 2 cm x 4 cm x 2 mt
Colors: Brown-Grey

SAFETY

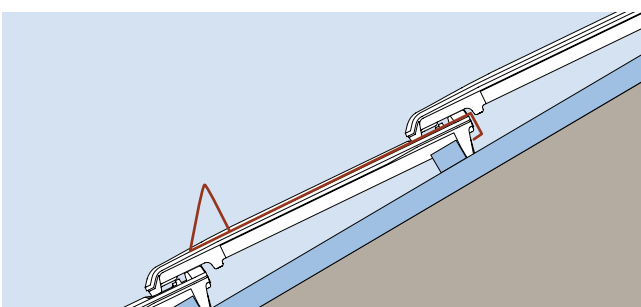

SNOW STOPPER HOOKS
CAM29 / CAM30

Metal hook system preventing snow gathering and falling off in block.

Dimensions: 140 x 17 mm
Colors: Red-Black.





Roof Maintenance and Care

06



Roof Maintenance and Care

06



Frequently asked questions: Roof Maintenance and Care

1. Why is ventilation so important?

Ventilation (known as micro-ventilation) between the tile and the supports beneath determines the tile's efficiency and the durability of the roof across the years.

The tiles are made from natural clays, giving them a certain porosity that enables them to "breathe" by absorbing and expelling water and holding moisture inside the building. To prevent condensation and dampness that lead to leaking into the home, the tiles must be installed in accordance with the relevant standards. Good ventilation and accessories that help this process are also important.

Ventilation enables air to flow beneath the tiles and allows them to dry. It also reduces the occurrence of moss and fungi, maintaining the appearance of the roof over time. Therefore, the ridge line must never be filled with cement or similar materials. Instead, it must remain open to facilitate air flow and be fitted with protection to stop birds, insects and small rodents from entering.

2. Why does condensation occur under a roof?

Condensation occurs when the temperature falls below the dew point of the surrounding area. This process usually occurs in winter and takes place when there is a difference of more than 2°C between the temperature and the cold surface (in still air). Condensation produces water droplets when the air is concentrated beneath an open roof as the temperature drops.

This condensation can lead to dampness and a subsequent deterioration of the roof due to fungi and other organisms.

It can be prevented by proper roof installation and ventilation, which helps air flow and dries out the dampness that can appear beneath the tiles.

3. Are water leaks due to the tiles?

Tiles are made from natural clay and are therefore porous. This porosity gives the material a degree of permeability, which La Escandella controls using a process of selecting, pressing and firing the clay to remove all potential for leakage caused by the tile. Permeability, along with other characteristics of La Escandella tiles, is measured and audited periodically by various domestic and international institutions, which have awarded La Escandella tiles the most rigorous quality certifications.

As a general rule, a roof usually leaks as a result of poor tile installation (insufficient slope, excessive use of mortar, lack of ventilation, the sealing of special points such as chimneys, joins with walls, etc.), which can affect its water tightness. Each different installation requires close monitoring by a roofing professional.

4. How can I prevent mildew on my roof?

Mildew, or moss as it is commonly known, is a micro-organism that appears on roofs, often due to the tiles (because of their porosity natural condition) being exposed to certain environmental conditions.

As per the 'CTE' (Spanish Building Technical Code), the following maintenance steps should be taken:

- **Once a year:** Water outlet and drainage elements should be cleaned (gutters, drains, ...).
- **Every 3 years approximately:** check the preservation of the roof and the Special pieces / Accessories.

These include nearby vegetation, a north-facing roof, an insufficient slope on the roof and pollution, as well as a lack of ventilation and the use of mortar.

It is almost impossible to prevent mildew because of the large range of factors that cause it to appear. However, correct dry installation, particularly avoiding the use of mortar, and the necessary micro-ventilation between the roof and its base are important factors in keeping it at bay.

We also recommend that the roof be cleaned every 3 to 5 years, depending on the home's location and climate. This removes any residues that may have accumulated, which can prevent the tiles from drying and correctly expelling rainwater

5. How can I prevent stains and white markings on the tiles?

White markings on tiles, known as efflorescence, appear on the tile surface due to salts or carbonates resulting from the use of too much water in mortars for installation, as well as excessive moisture and a lack of roof ventilation. The moisture is expelled by the most well-ventilated areas. This water then evaporates, leaving salt deposits which cause white staining on the tiles.

Despite rigorous controls over salt levels in tiles, mortars and the water used with them can cause efflorescence. This commonly occurs during installation and can be easily countered by dampening the tiles with water and allowing them to dry (provided installation requirements have been met, particularly in relation to roof ventilation).

Where the problem occurs subsequent to installation, it must always be analysed and treated by specialists who will not only remove the efflorescence but correct the problems causing it. Normally they will clean the

area with water, and even vinegar, treating the salts and removing the surface stains. However, it is always advisable that each case be studied individually and a solution prescribed depending on the type of tile, installation and other architectural details.

6. How can I prevent the tiles from deteriorating in very salty climates?

In regions prone to adverse weather conditions, particularly those close to the sea, special attention must be paid to roof installation. Good ventilation is even more important in preventing the accumulation of salts or other organisms that can deteriorate the tiles.

Micro-ventilation (between the supports and the tiles) allows the tiles to be properly ventilated, quickly drying any moisture caused by proximity to the sea, by rain, etc. and making the tiles, and ultimately the roof, more durable.

Colours:

1. Can I mix different coloured tiles? Examples.

Of course. As long as the same shape is used, colours can be mixed to create unique, fully customised combinations. You can view a range of combinations in our gallery, which mix up to 3 or 4 colours in the one roof. You can also consult our technical department for advice on the best combinations for your home.

2. What are the advantages of glazing compared to the powdered finish?

As well as offering a bright finish, glazing repels water from the surface of the tile, helping colours stay more durable over time. Always taking care that the tiles have been properly installed, making the roof as durable and functional as possible. Good ventilation under the tiles from the eaves to the ridge is required, using ventilation tiles based on the length of the gable.

3. Does the colour of the tile affect a home's temperature?

Ceramic roofs help with thermal insulation, adding up to +3° in the winter and -3° in the summer. This promotes energy savings in the home.

As with any other material, dark colours will hold more heat. For this reason, lighter colours tend to be used in warmer regions, while redder, darker colours are used where the climate is cooler.

Regardless of climactic conditions, it is worth nothing that clay tiles offer a higher degree of thermal insulation than other metal or plastic products or concrete

tiles. This superior thermal performance is increased when tiles are correctly installed, particularly in relation to the slope of the roof and under-tile ventilation.

4. Are there shade variations in tiles of the same colour? How do I stop these from being obvious?

Tiles are made with different clay combinations and, because clay is a natural material, it can exhibit slight variations in shade after firing. This can be accentuated more in white clays, as they are more susceptible to this phenomenon.

To achieve a more uniform roof colouring, which doesn't show up small variations, we recommend mixing tiles from across the pallet range, given that tiles are not installed according to a set order based on finish.

La Escandella Tiles:



What does the La Escandella guarantee cover?

Cerámica La Escandella guarantees that its ceramic tiles and accessories are free from manufacturing defects (including frost resistance) with Guarantees depending on the type of product: 35 years for the Mediterranean Range (Curve, Mixed and Flat) and 100 years for The H-Selection Range (Visum3, Planum, Vienna and Innova).

La Escandella Guarantee will be applied/valid only if the following requirements are committed.

- The manufacturer's instructions and the technical code of the country have been complied with and particularly that referring to the ventilation of the deck.
- All tiles and accessories installed have been manufactured by La Escandella and are those recommended by this manufacturer for a proper construction of the deck. Any painted, varnished, hydrofuged tiles subjected to any treatment not carried out by La Escandella, shall not be covered by this guarantee.
- This guarantee does not apply in case of defects which are visible on the delivery of the tiles such as differences in the tonality or damages caused by the transportation. Additionally, due to the nature of the tiles as well as the possible effects of the surrounding environment, La Escandella shall not be responsible for changes in tonality or ageing of the tiles.
- The guarantee entails the free disposal of the material delivered under conditions EXW (Ex work). Neither the costs arisen from the removal of the defective tiles or transportation or installation of new ones, nor indirect damages which may have been caused are included.

Excluded from this guarantee:

1. Water leaks due to a faulty laying of the tiles are excluded from this certification.
2. Any damage caused by movement, distortion, cracking or settling of the walls or foundation of the building.
3. Any damage caused by the impact of objects, fire, earthquakes, flooding... or any force majeure.

The Guarantee is not applied for visible damages during the delivery of the tile as well as differences in the tonality or damages caused during the transport. Due to the natural characteristics of the tiles, as well as the possible effects of the environment, La Escandella is not responsible for possible changes of tonality or aging effects in the tiles.



07

Glossary



Glossary

Definitions of roof and roofing components

Field or skirt: each of the sloped planes that form the roof.

Maximum slope line: the trajectory described by the free flow of water down a field.

Right of a field or skirt: the right hand side of the field in the direction of the flow of water. Looking facing the roof from the eaves, it is the right-hand section of the field.

Left of a field or skirt: the left hand side of the field in the direction of the flow of water. Looking facing the roof from the eaves, it is the left-hand section of the field.

Eaves: the overhanging edge of the slope of a roof, thanks to which the water collected by the roof does not fall on the vertical wall.

Valley: the line of intersection of two fields of a roof, into which water runs.

Hip: the sloping line created by the intersection of two fields, from which the water is distributed onto these fields.

Ridge: the horizontal line created by the intersection of two fields (pitched or gable roof), or a field with a vertical slope (mono-pitched roof).

Lateral side edge: the top of the a field that is not protected by any higher-level element.

Gable: supporting wall delineated by the roof above.

Structural foundation: responsible for giving stability to the whole and defining the layout of the pitches. The material components of the structural foundation must meet appropriate standards.

Support: the component on which the roof rests and by which it is maintained. It can be continuous or interrupted. When it is continuous it is referred to as deck and be made up of hollow ceramic bricks with a mortar or cement finish, fibre cement panels, various types of sheeting, etc. Discontinuous supports are made up of battens, sheeting, etc.

Brace: element parallel to the maximum slope of the field, which acts as a support for the straps.

Strap: element perpendicular to the maximum slope of the field, which acts as a support for the slats. In certain cases it can act as the ridge.

Joist or rafter: element parallel to the maximum slope of the field, which acts as a support for the battens.

Batten: element that acts as a support for the tiles.

Fixing or fastening: the process by which the roof covering is attached to the support. Depending on the slope, fastenings may be tacks, staples, mortar, glue, silicon, etc.

Roof covering: the roof covering is the element that is in direct contact with meteorological elements, and which protects the rest of the components from these. It can be made up of continuous or discontinuous elements, and must be compatible with the frame supporting it and with the slope of the frame. The Clay Roof Tile is the subject covered in this manual.

Accessories: these are elements used for a perfect installation of the roof, the use of which will depend on the specific characteristics of each case. Accessories include: waterproof membranes, zinc sheeting, thermal insulation, guttering, etc.

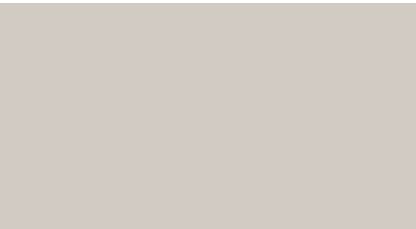



La Escandella

ROOFING THE WORLD

www.laescandella.com

La Escandella

ROOFING THE WORLD

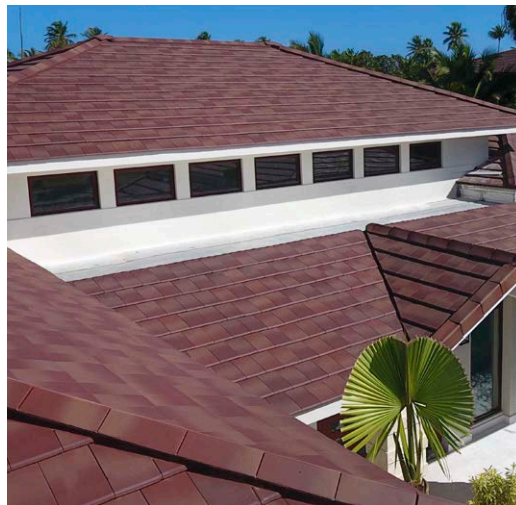

www.laescandella.com

